

CATALOGUE

DISTRICT HEATING / COOLING

PRE - INSULATED PIPE SYSTEMS



Saules 8, Ozolnieki,
Ozolnieku pag.,
Jelgavas nov., LV-3018
Tel. +371 630 50 600
email: info@poliurs.lv
www.poliurs.lv

POLIURS

v.1.2022



CONTENT

1 **POLIURS**

INTRODUCTION

2



GENERAL INFORMATION

3



SINGLE PIPES / FITTINGS

4



TWIN PIPES / FITTINGS

5



SINGLE PIPES / FITTINGS IN SPIRO CASING

6



JOINTS

7



ACCESSORIES

Currently for district heating networks the preinsulated pipes are most widely used. The main advantages of preinsulated pipes are:

- minimal heat losses;
- long service life (30-50 years) with minimal maintenance demands;
- simple assembly of joints, providing efficient thermal insulation and waterproofing;
- concrete duct is not necessary, pipes are laid in the trench on sand layer;
- electronic moisture surveillance system is available.

“POLIURS” Ltd. has specialized in the production of preinsulated pipes for district heating since January, 1995. Special attention is devoted towards high quality of the product and protection of surrounding environment. Developed quality system is certified according to standards ISO 9001 and ISO 14001. Introduced ISO 9001 and ISO 14001 Quality Management Systems ensure that the products of “POLIURS” Ltd. are manufactured according to the European standards:

- EN 253. District heating pipes - Pipe assembly of steel service pipes, polyurethane thermal insulation and outer casing of polyethylene.
- EN 448. District heating pipes - Fitting assemblies of steel service pipes, polyurethane thermal insulation and outer casing of polyethylene.
- EN 488. District heating pipes - Steel valve assembly for steel service pipes, polyurethane thermal insulation and outer casing of polyethylene.
- EN 489. District heating pipes - Joint assembly for steel service pipes, polyurethane thermal insulation and outer casing of polyethylene.
- EN 13941-1. Design and installation of thermal insulated bonded single and twin pipe systems for directly buried hot water networks - design.
- EN 13941-2. Design and installation of thermal insulated bonded single and twin pipe systems for directly buried hot water networks - installation.
- EN 14419. Surveillance system.
- EN 15698-1. Twin pipe systems, Part 1: Factory made fittings
- EN 15698-2. Twin pipe systems, Part 2: Factory made fittings and valve assemblies

In addition to traditional products described in catalogue “POLIURS” Ltd. offers individually designed pipes and fittings on the customer demand. Individual solutions can remarkably reduce the volume of installation works and the expenses required. Company’s staff consults customers in all aspects regarding optimal choice of pipe installation.

A preinsulated bonded pipe for district heating is a sandwich construction consisting of three main components:

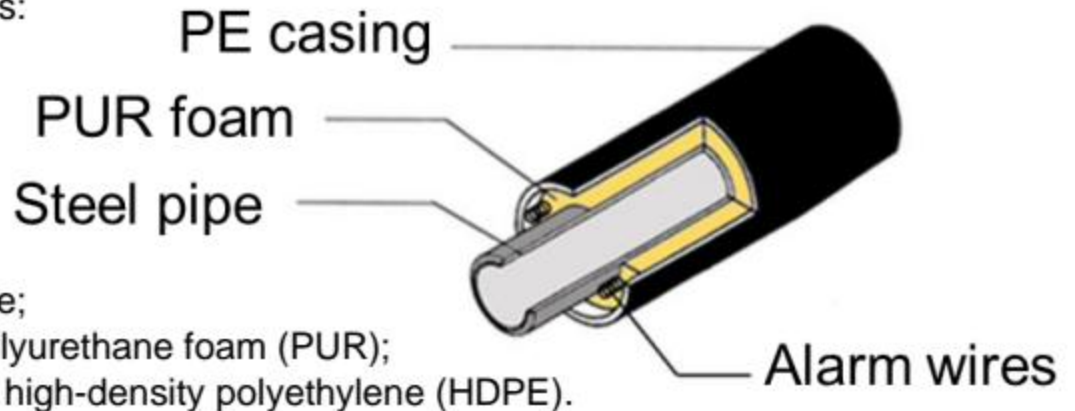

- a steel service pipe;
- an insulation of polyurethane foam (PUR);
- an outer casing of high-density polyethylene (HDPE).

"Poliurs" Ltd. produces preinsulated bonded pipes and their fittings with diameters of main service pipes from 20 to 1000 mm (3/4 - 39 inches). Depending on diameter of used casing pipe for each service pipe 4 different thicknesses of foam insulation layers are possible, 4 insulation series.

"Poliurs" Ltd. also produces preinsulated pipes and fittings for special application:

- preinsulated pipes and fittings with galvanized spiral steel casing;
- pipes and fittings with two-layer insulation for temperatures 150 - 250°C;
- preinsulated double pipes and fittings, where under one casing are located two pipes: preheated and return pipes;
- preinsulated pipes with heating cable.

Preinsulated pipes are equipped with alarm system wires that certify pipeline correspondence to the technical specifications when it becomes operational, also makes an operator known in case of a potential accident and discovers its exact location. The surveillance of the pipeline can be automatically. Assortment of preinsulated pipes and fittings enables to construct pipeline in complicated geographical region (including overcoming of water barriers) and in the cities.

On costumers' request, the company can supply fittings of the individualized construction.

Different technical ways and means are offered for compensation of thermal expansion deformation and its effect decrease.

The company meets the customers' needs concerning additional materials for the assembly of pipeline and fittings.

Company consults and train clients of necessary rules regarding pipe assembly, and offers technical surveillance of the pipeline installation (during assembly and acceptance of the pipeline).

The company "POLIURS" Ltd. Quality Management System correspondingly to ISO 9001 demands includes all structural entities and staff, which are connected to the production of the heat insulated products and client relationship. The company uses only certified resources for production of pipes, fittings and its accessories. The staff of the company is qualified and certified. All main parameters of the production process are controlled and recorded; staff involved in the production is also registered. That way high level of responsibility is achieved. The personal responsibility for one's own duties is the main guarantee of the company's production.

ISO 9001 and ISO 14001 have been proved and certified by "Bureau Veritas Quality International" that is the leading world firm in certification.

"POLIURS" Ltd. guarantees that the operational time of the manufactured preinsulated bonded pipes and joints is 5 (five) years, if following conditions are fulfilled:

- comply with instructions for transportation, storage, assembly and operation, which are included in "Heating main montage instructions CV4.04."
- ensures following pipeline parameters:
 - working pressure $\leq 16; 25$ bar;
 - temperature $\leq 140^{\circ}\text{C}$;
 - salinity < 3000 mg/l;
 - pH 9,5 -10;
 - free oxygen not permissible.

The company "POLIURS" Ltd. provides its consumers with the special quality certificate on all their products.

"POLIURS" Ltd. is constantly working on widening its assortment of produced items, improving product quality and offered services.

RISE tests our products once per year on the basis of the functional requirements in EN 253, EN 448 and the Euroheat & Power certification guidelines.



All steel service pipes, pipe casings and insulation material used in assembly of preinsulated pipes and fittings comply with European Standard - EN 253.

Main parameters:

1. Steel service pipe:

- nominal diameters DN: 20 - 1000 mm;
- steel grades P235GH EN 10217-2;
- upper yield strength, min: 235 MPa;
- tensile strength, min: 360 - 500 MPa.

Steel pipe DN	Outer diameter [mm]	Nominal wall thickness [mm]
20	26.9	2.0
25	33.7	2.6
32	42.4	2.9
40	48.3	2.9
50	60.3	2.9
65	76.1	2.9
80	88.9	3.2
100	114.3	3.6
125	139.7	3.6
150	168.3	4.0
200	219.1	4.5
250	273.0	5.0
300	323.9	5.6
350	355.6	5.6
400	406.4	6.3
450	457.0	6.3
500	508.0	6.3
600	610.0	7.1
700	711.0	8.0
800	813.0	8.8
900	914.0	10.0
1000	1016.0	11.0

1. Pipe casings:

- material: HDPE PE100;
- wall thickness according to EN 253;
- minimum density: 944 kg/m³.

Diameter [mm]	Minimum wall thickness [mm]
90	3.0
110	3.0
125	3.0
140	3.0
160	3.0
180	3.0
200	3.2
225	3.4
250	3.6
280	3.9
315	4.1
355	4.5
400	4.8
450	5.2
500	5.6
560	6.0
630	6.6
710	7.2
800	7.9
900	8.7
1000	9.4
1100	10.2
1200	11.0

2. Thermal insulation:

- material: PUR (polyurethane foam);
- PUR components: polyol and isocyanate;
- blowing agent: CYCLOPENTANE;
- thermal conductivity: 0.026 W/m^{°K}



Pipes

3.1.1. – 3.1.8.



Bends

3.2.1. – 3.2.2



T-pieces

3.3.1. – 3.3.5.



Air vent/drain units

3.3.6. – 3.3.7.



Valves

3.4.1. – 3.4.2.



**Valves with
air vent/drain units**

3.4.3. – 3.4.5.



**By-pass valves
3.4.6. – 3.4.8.**



**Compact valve blocks
3.4.9.**

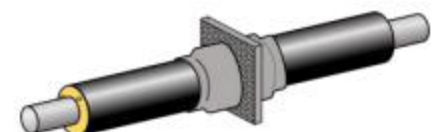

**Fixed anchors
3.5.1.**



**Compensators
3.5.2.**



**Diameter reducers
3.5.3.**

Preinsulated single pipes

3.1.1.

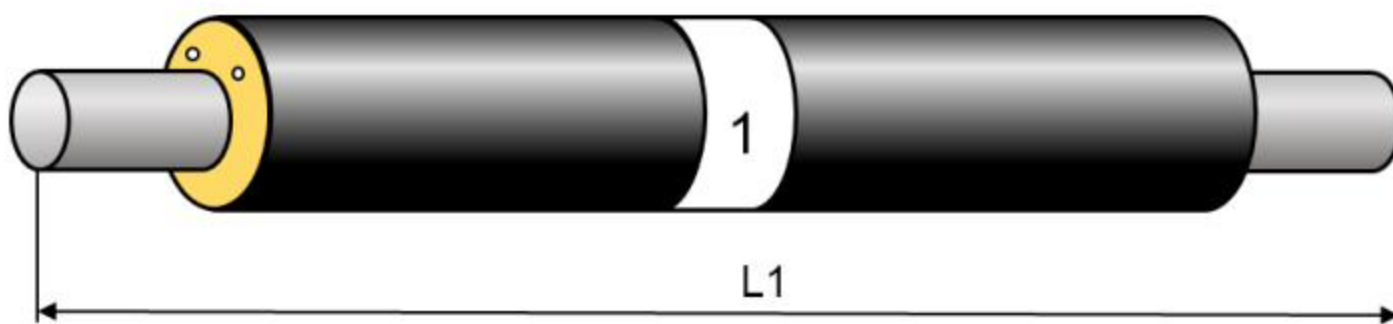

Series 1

Main pipe DN	PE casing pipe [mm]	Weight [kg/m]	Water content [l/m]	Transfer capacity $\Delta T = 50\text{ }^{\circ}\text{C}$ [kW]
20	90	2,4	0,4	65
25	90	3,1	0,6	100
32	110	4,3	1,1	180
40	110	4,6	1,5	230
50	125	6,1	2,3	370
65	140	7,4	3,5	700
80	160	9,4	5,3	1 000
100	200	13,6	9,0	1 800
125	225	16,6	13,8	3 300
150	250	21,5	20,2	5 000
200	315	31,9	34,7	10 000
250	400	43,9	54,3	18 000
300	450	60,0	76,8	28 000
350	500	68,3	93,1	34 000
400	560	86,9	121,7	45 000
450	630	101,0	155,0	65 000
500	710	105,4	193,0	80 000
600	800	138,0	277,0	110 000
700	900	190,2	378,0	160 000
800	1000	246,0	497,0	210 000
900	1100	276,0	627,0	265 000
1000	1200	342,0	776,0	330 000

Pipe length **L1** can be ordered 6; 12; 16; 18 m.

Material of service pipe - steel. On request - copper or stainless steel.

Material of casing pipe - high density polyethylene (PE100).

Preinsulated single pipes

3.1.2.

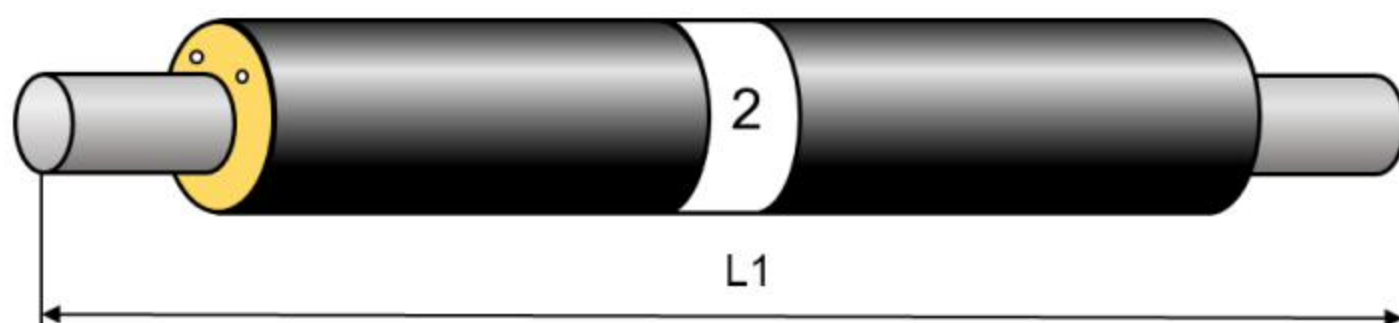

Series 2

Main pipe DN	PE casing pipe [mm]	Weight [kg/m]	Water content [l/m]	Transfer capacity $\Delta T = 50\text{ }^{\circ}\text{C}$ [kW]
20	110	3,3	0,4	65
25	110	3,5	0,6	100
32	125	4,6	1,1	180
40	125	5,0	1,5	230
50	140	6,5	2,3	370
65	160	8,0	3,5	700
80	180	10,1	5,3	1 000
100	225	14,8	9,0	1 800
125	250	17,7	13,8	3 300
150	280	23,6	20,2	5 000
200	355	35,1	34,7	10 000
250	450	47,0	54,3	18 000
300	500	65,5	76,8	28 000
350	560	75,7	93,1	34 000
400	630	96,3	121,7	45 000
450	710	113,5	155,0	65 000
500	800	118,0	193,0	80 000
600	900	153,6	277,0	110 000
700	1000	210,0	378,0	160 000
800	1100	267,0	497,0	210 000
900	1200	305,6	627,0	265 000

Pipe length **L1** can be ordered 6; 12; 16; 18 m.

Material of service pipe - steel. On request - copper or stainless steel.

Material of casing pipe - high density polyethylene (HDPE).

Preinsulated single pipes

3.1.3.

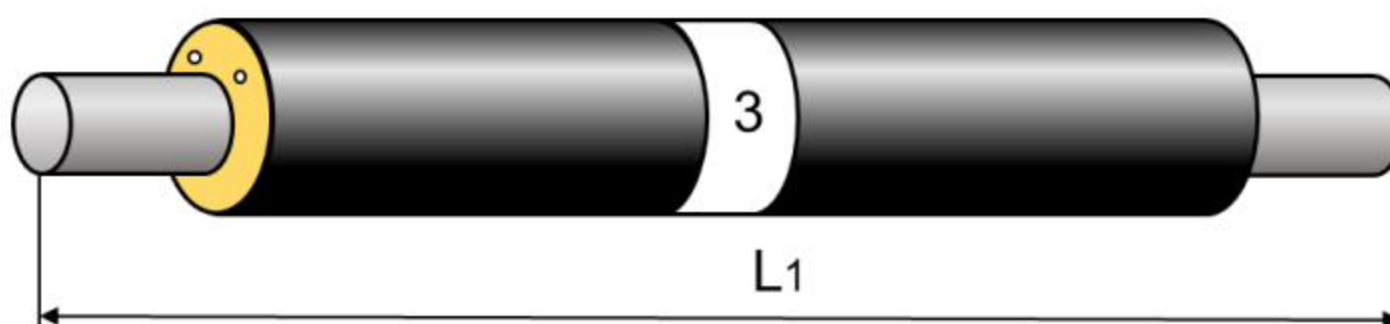

Series 3

Main pipe DN	PE casing pipe [mm]	Weight [kg/m]	Water content [l/m]	Transfer capacity $\Delta T = 50 \text{ }^\circ\text{C}$ [kW]
20	125	3,7	0,4	65
25	125	3,9	0,6	100
32	140	5,0	1,1	180
40	140	5,4	1,5	230
50	160	7,1	2,3	370
65	180	8,7	3,5	700
80	200	10,9	5,3	1 000
100	250	16,2	9,0	1 800
125	280	19,9	13,8	3 300
150	315	25,7	20,2	5 000
200	400	39,0	34,7	10 000
250	500	51,4	54,3	18 000
300	560	76,9	76,8	28 000
350	630	85,1	93,1	34 000
400	710	108,8	121,7	45 000
450	800	124,0	155,0	65 000
500	900	147,0	193,0	80 000
600	1000	189,0	277,0	110 000
700	1100	248,0	378,0	160 000
800	1200	289,0	497,0	210 000

Pipe length L_1 can be ordered 6; 12; 16; 18 m.

Material of service pipe - steel. On request - copper or stainless steel.

Material of casing pipe - high density polyethylene (HDPE).

Preinsulated single pipes

3.1.4.

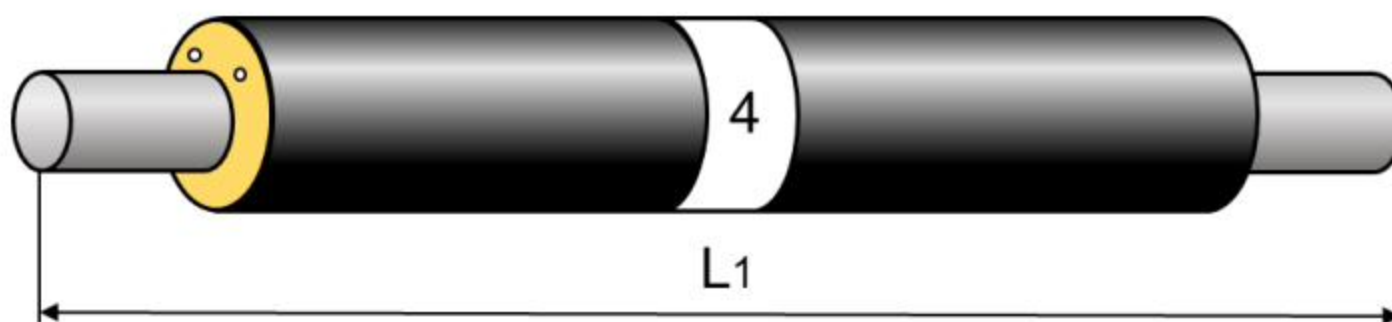

Series 4

Main pipe DN	PE casing pipe D [mm]	Weight [kg/m]	Water content [l/m]	Transfer capacity $\Delta T = 50\text{ }^{\circ}\text{C}$ [kW]
20	140	4,1	0,4	65
25	140	4,4	0,6	100
32	160	5,5	1,1	180
40	160	6,0	1,5	230
50	180	7,8	2,3	370
65	200	9,6	3,5	700
80	225	11,9	5,3	1 000
100	280	17,4	9,0	1 800
125	315	22,5	13,8	3 300
150	355	28,0	20,2	5 000
200	450	42,0	34,7	10 000
250	560	56,6	54,3	18 000
300	630	82,5	76,8	28 000
350	710	93,5	93,1	34 000
400	800	119,0	121,7	45 000
450	900	139,0	155,0	65 000
500	1000	162,0	193,0	80 000
600	1100	207,0	277,0	110 000
700	1200	259,0	378,0	160 000

Pipe length L_1 can be ordered 6; 12; 16; 18 m.

Material of service pipe - steel. On request - copper or stainless steel.

Material of casing pipe - high density polyethylene (HDPE).

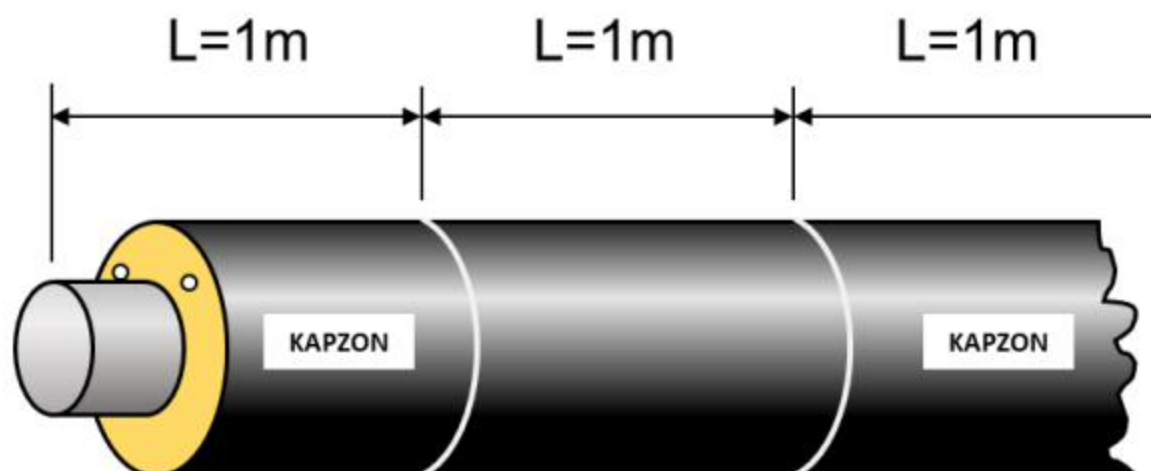

Series 1, 2, 3 and 4

Steel service pipe is covered by a plastic foil every second meter along the entire pipe length. This arrangement allows easy removal of the foam from the steel in the sections which are indicated on the outside casing pipe. Whole lengths or parts of pipes cut-to-length can be installed at any place.

L1 segments can be ordered on 6; 12; 16; 18 m long pipes.

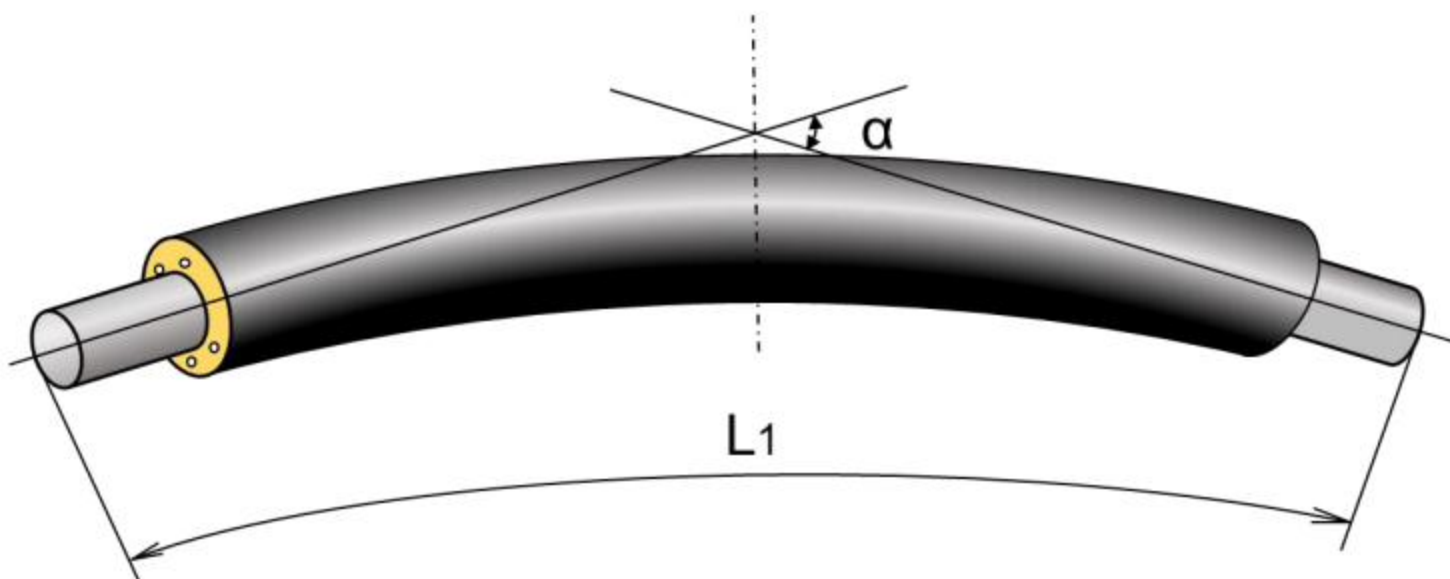

Series 1, 2, 3 and 4

Main pipe DN	Max deflection angle L1= 12m	Max deflection angle L1 = 16m
25 – 50	45°	45°
50 – 80	45°	45°
100 – 150	45°	45°
200 – 250	35°	35°
300	30°	30°
350	20°	20°
400	18°	18°
500	9°	9°

Allowable accuracy: DN 25 - 80 mm +/- 3°

DN 100 - 250 mm +/- 2°

DN 300 - 500 mm +/- 1°

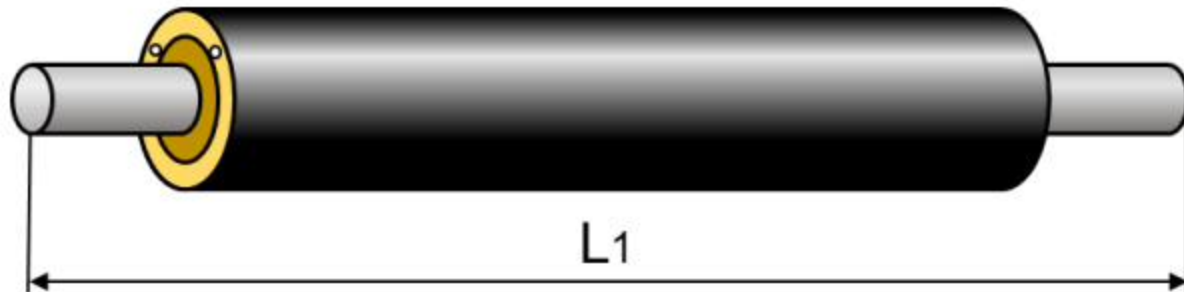
Pipes with two-layer insulation (150 – 250 °C)**3.1.7.**

Main pipe DN	PE casing pipe [mm]			
	Series 1	Series 2	Series 3	Series 4
20	125	140	160	180
25	125	140	160	180
32	140	160	180	200
40	140	160	180	200
50	160	180	200	225
65	180	200	225	250
80	200	225	250	280
100	250	280	315	355
125	280	315	355	400
150	315	355	400	450
200	400	450	500	560
250	450	500	560	630
300	500	560	630	710
350	560	630	710	800
400	630	710	800	900

Custom made product.

Insulation:

- inner rock wool layer
- outer layer of polypropylene (PUR) foam or PIR foam.

Pipe length **L1** can be ordered 6; 12; 16; 18 m.

Preinsulated pipes with protectors

3.1.7.

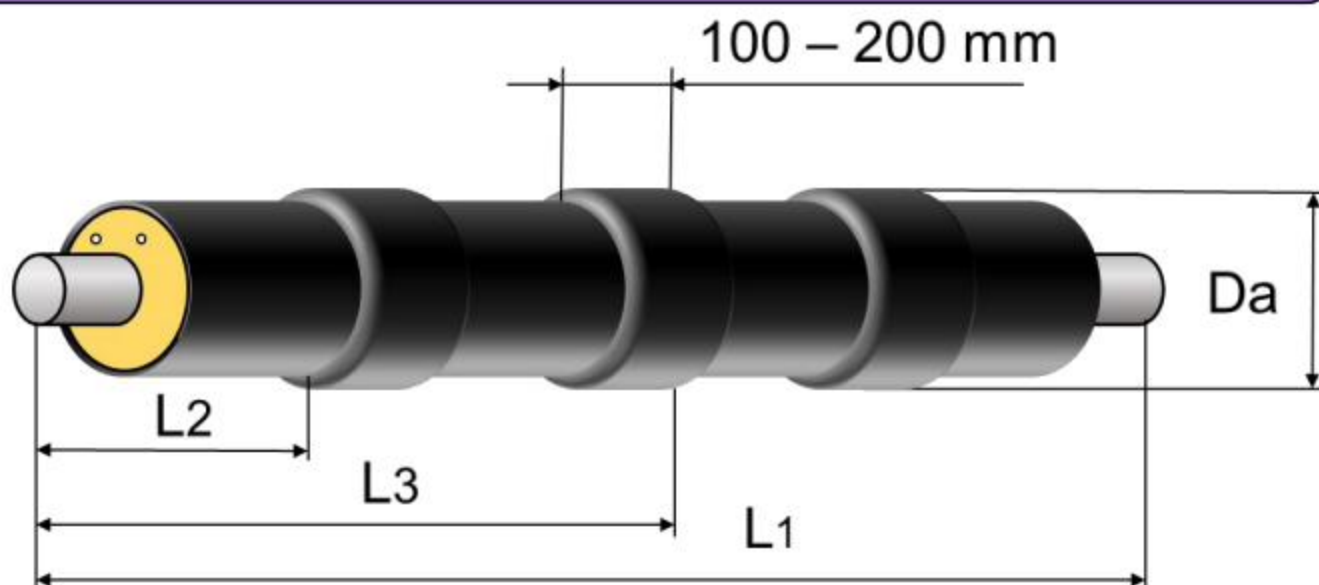

Main pipe DN	Total PE pipe diameter D_a [mm]			
	Series 1	Series 2	Series 3	Series 4
20	124	144	159	174
25	124	144	159	174
32	144	159	174	198
40	144	174	198	218
50	159	174	198	218
65	174	198	218	239
80	198	218	239	264
100	239	264	290	321
125	264	290	321	357
150	290	321	357	444
200	357	399	444	497
250	444	497	548	610
300	497	548	610	680
350	548	610	680	760
400	610	680	760	850
500	760	860	960	-
600	860	960	1060	-
700	960	1060	1160	-
800	1060	1160	1260	-
900	1160	1260	-	-
1000	1260	-	-	-

Pipe length L_1 can be ordered 6; 12; 16; 18 m.

Pipes with protectors are used in closed canals (pipes) – under the road or buildings.
Minimal protector count per pipes is 2 pcs.

Depending on preinsulated pipe length you can choose distance between protectors:
 $L_2 = 1.0 - 1.5\text{m}$ and $L_3 = 2.0 - 3.5\text{m}$.

Preinsulated bend

3.2.1.

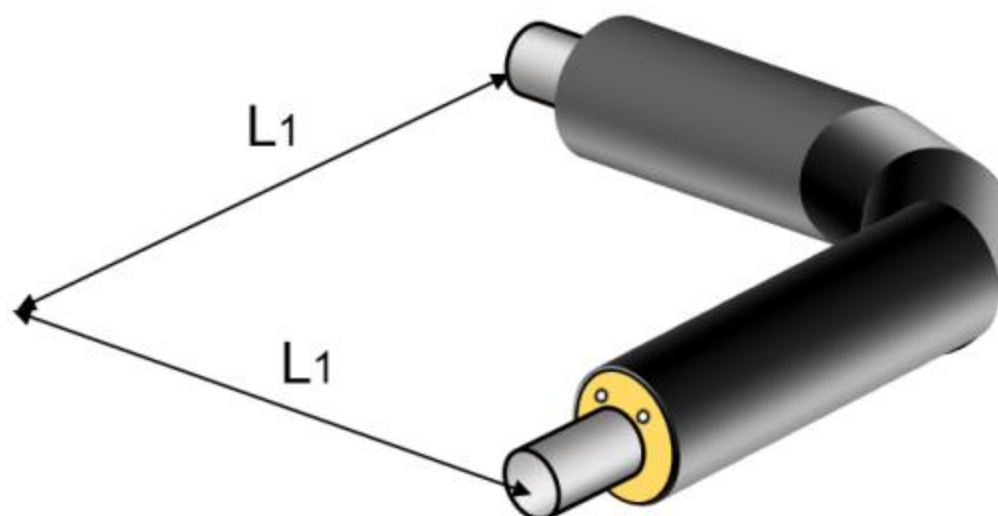

Main pipe DN	PE casing pipe [mm]				L1 [mm]
	Series 1	Series 2	Series 3	Series 4	
20	90	110	125	140	1000
25	90	110	125	140	1000
32	110	125	140	160	1000
40	110	125	140	160	1000
50	125	140	160	180	1000
65	140	160	180	200	1000
80	160	180	200	225	1000
100	200	225	250	280	1000
125	225	250	280	315	1000
150	250	280	315	355	1000
200	315	355	400	450	1000
250	400	450	500	560	1300
300	450	500	560	630	1500
350	500	560	630	710	1600
400	560	630	710	800	1600
450	630	710	800	900	1600
500	710	800	900	1000	1600
600	800	900	1000	1100	1600
700	900	1000	1100	1200	1700

Standard bends are 90°.

Upon request: degrees from 5° to 90°
 leg length up to 10.0 m
 dimensions greater than DN700

Preinsulated vertical bends

3.2.2.

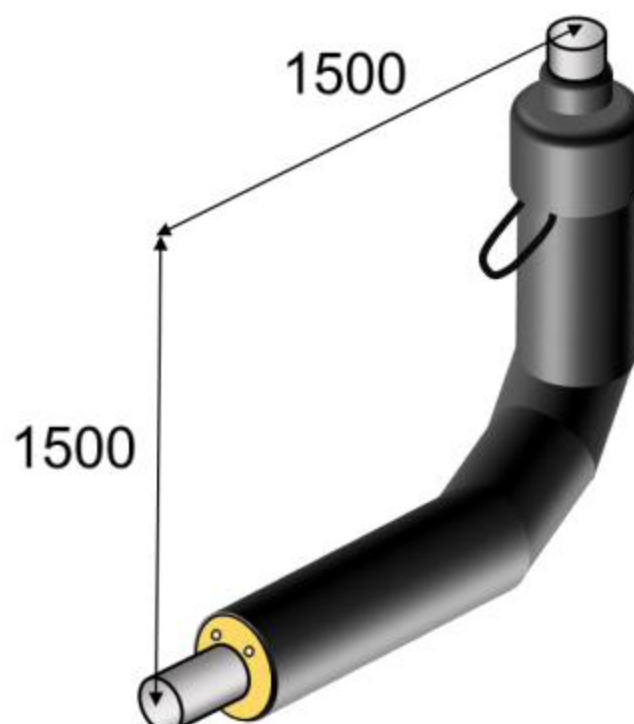

Main pipe DN	PE casing pipe [mm]			
	Series 1	Series 2	Series 3	Series 4
20	90	110	125	140
25	90	110	125	140
32	110	125	140	160
40	110	125	140	160
50	125	140	160	180
65	140	160	180	200
80	160	180	200	225
100	200	225	250	280
125	225	250	280	315
150	250	280	315	355
200	315	355	400	450
250	400	450	500	560
300	450	500	560	630
350	500	560	630	710
400	560	630	710	800
450	630	710	800	900
500	710	800	900	1000
600	800	900	1000	1100
700	900	1000	1100	1200

Vertical bends are most commonly used for heating pipeline entering the buildings.

Bends with length up to 10.0 m are made upon the request.

Can be ordered without an end cap.

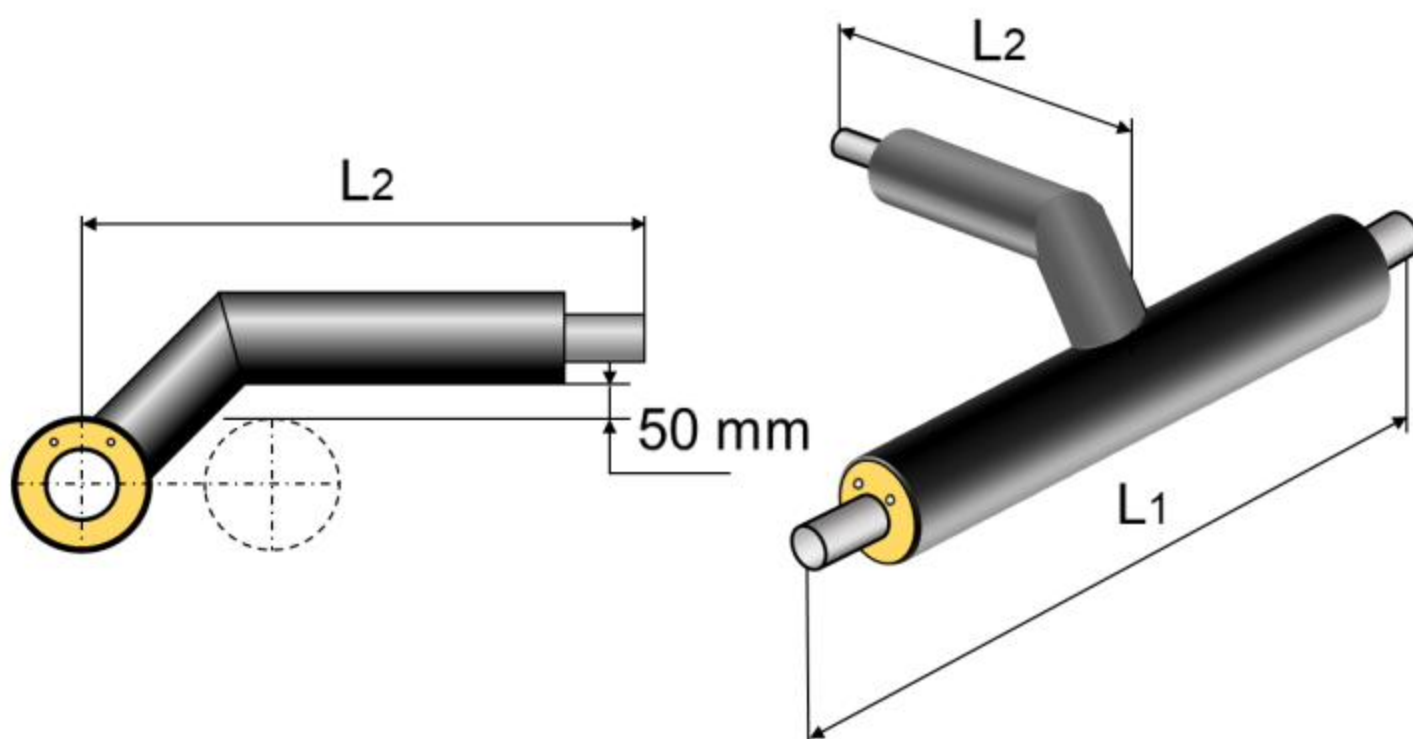

Series 1, 2, 3 and 4

Main pipe DN	Branch pipe DN	L1 [mm]	L2 [mm]
25 – 200	20 – 80	1200	1000
100 – 200	100 – 200	1500	1000
250 – 1000	25 – 80	1200	1200
250 – 1000	100 – 200	1500	1200
250 – 1000	250 – 400	1800	1500
600 – 1000	500 – 1000	2100	2100

Diameter of branch **L2** cannot be greater than diameter of main pipe **L1**.

T-pieces can be made upon the request:

- with a custom angle of branch pipe to the main pipe.

Preinsulated perpendicular extended T-branches

3.3.2.

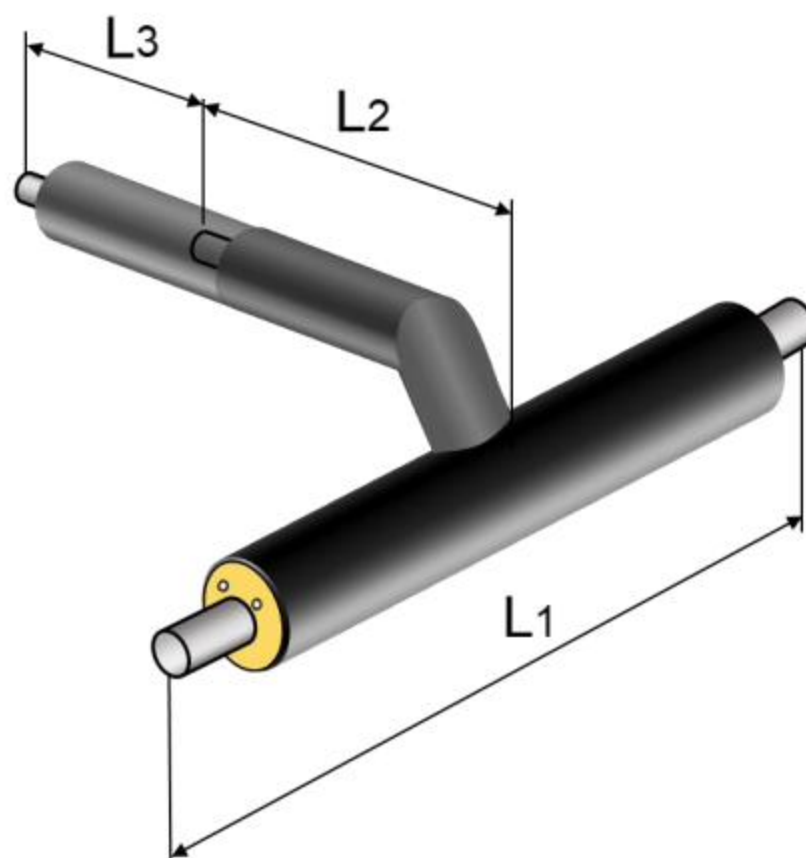

Series 1, 2, 3 and 4

Main pipe DN	For L1 and L2 see page 3.3.1.	L3 [mm] Series 1 and 2	L3 [mm] Series 3 and 4
25 – 50		330	530
65 – 80		370	570
100 – 125		500	600
150		530	630
200		600	700
250		700	800
300		750	860
350		850	930
400		930	1000
500		1000	1100
600		1100	1200
700		1200	1300
800		1300	1400
900		1400	1500
1000		1500	1600

Preinsulated perpendicular T-branches with reducer 3.3.3.

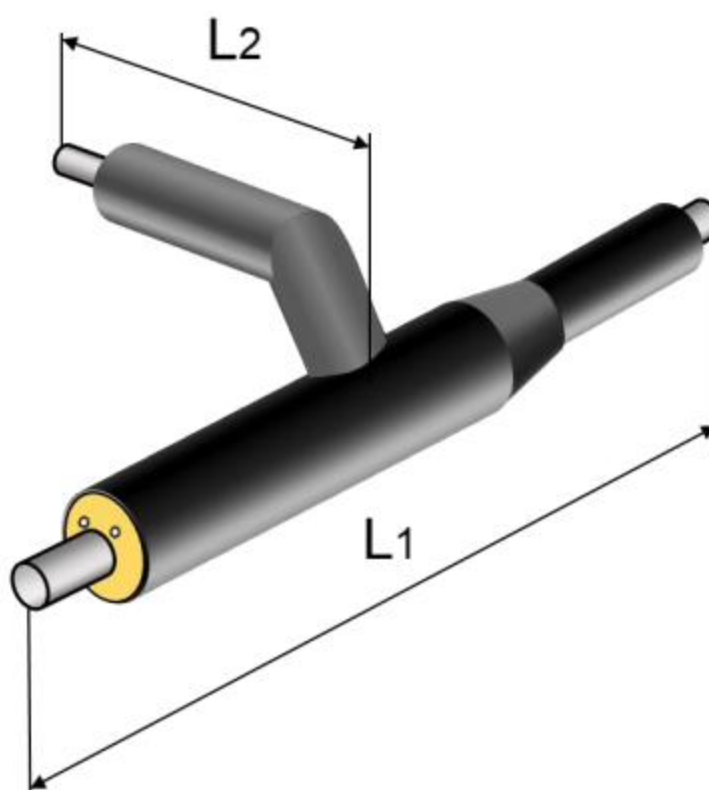

Series 1, 2, 3 and 4

Main pipe DN	Branch pipe DN	L1 [mm]	L2 [mm]
25 – 200	20 – 80	1200	1000
100 – 200	100 – 200	1500	1000
250 – 1000	25 – 80	1200	1200
250 – 1000	100 – 200	1500	1200
250 – 1000	250 – 400	1800	1500
600 – 1000	500 – 1000	2100	2100

Pipe reducer can be ordered with reduction between 1-3 dimension levels.

Diameter of branch **L2** cannot be greater than the diameter of main pipe.

On request T-pieces can be produced with any angle of branch pipe to the main pipe.

When ordering it is mandatory to inform of T-piece preference: right or left. On the drawing the T-piece is shown with left transition.

Preinsulated straight T-branches

3.3.4.

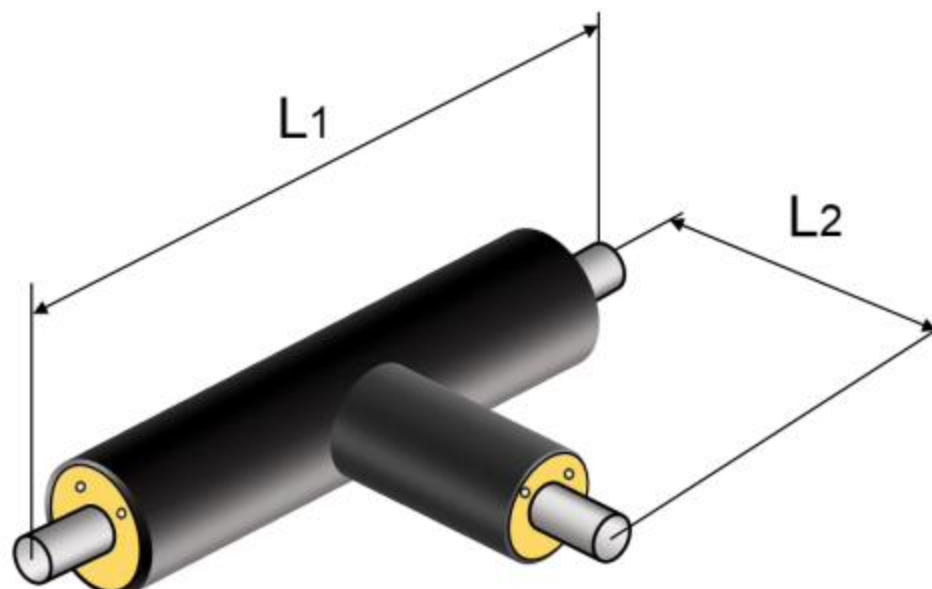

Series 1, 2, 3 and 4

Main pipe DN	Branch pipe DN	L1 [mm]	L2 [mm]
25 – 200	20 – 100	1200	700
125 – 200	125 – 200	1500	700
250 – 500	25 – 200	1500	900
250 – 500	250 – 400	1800	900
600 – 1000	25 – 500	1800	1100
600 – 1000	600 – 900	2100	1100

Diameter of branch **L1** cannot be greater than diameter of main pipe **L2**.

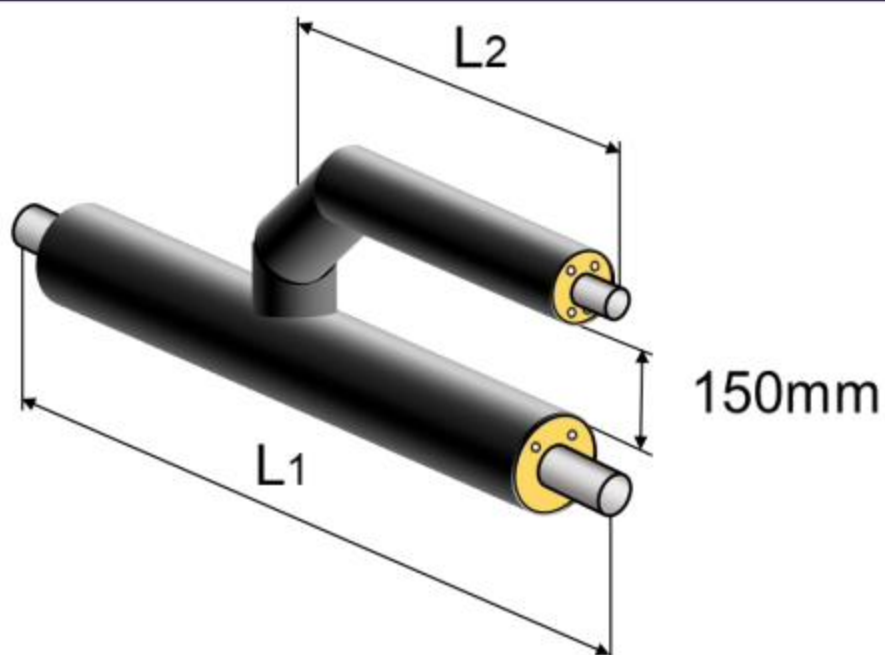

Series 1, 2, 3 and 4

Main pipe DN	Branch pipe DN	L1 [mm]
25 – 1000	20 – 100	1200
100 – 1000	125 – 200	1500
250 – 1000	250 – 400	1800
450 – 1000	450 – 500	2400
700 – 1000	600 – 700	3000

$$L2 = 0.5 * L1$$

Upon the request following parallel T-pieces can be made:

- with a custom angle of branch pipe to the main pipe.

T-branches with air vent/drain unit

3.3.6.

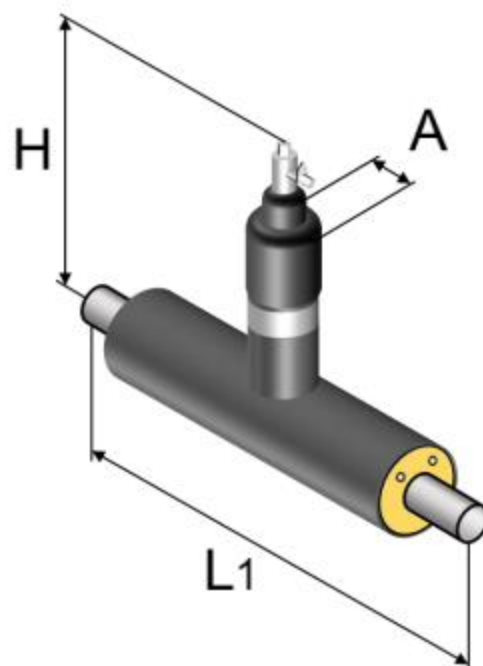

Main pipe DN	Service valve				L1 [mm]
	Air release valve		Drainage valve		
	DN	A [mm]	DN	A [mm]	
25	20	110	20	110	1 200
32	20	110	25	110	1 200
40	20	110	32	125	1 200
50	25	110	32	125	1 200
65	25	110	32	125	1 200
80	32	125	40	125	1 200
100	32	125	50	140	1 200
125	40	125	50	140	1 200
150	40	125	80	180	1 200
200	50	140	100	225	1 200
250	50	140	100	225	1 200
300	50	140	100	225	1 200
350	65	160	125	225	1 200
400	65	160	125	225	1 200
450	65	160	125	225	1 200
500	65	160	150	250	1 200
600	80	180	200	315	1 200
700	80	180	200	315	1 200
800	100	225	250	400	1 200

Used for air release or water drainage. Minimal stem height is $H_{min} = 400$ mm.

Also available:

- higher stem height H ;
- available in stainless steel top with PE protective cover;
- different air release sizes, than specified in table.



POLIURS

Preinsulated T-branches with drain unit

3.3.7.

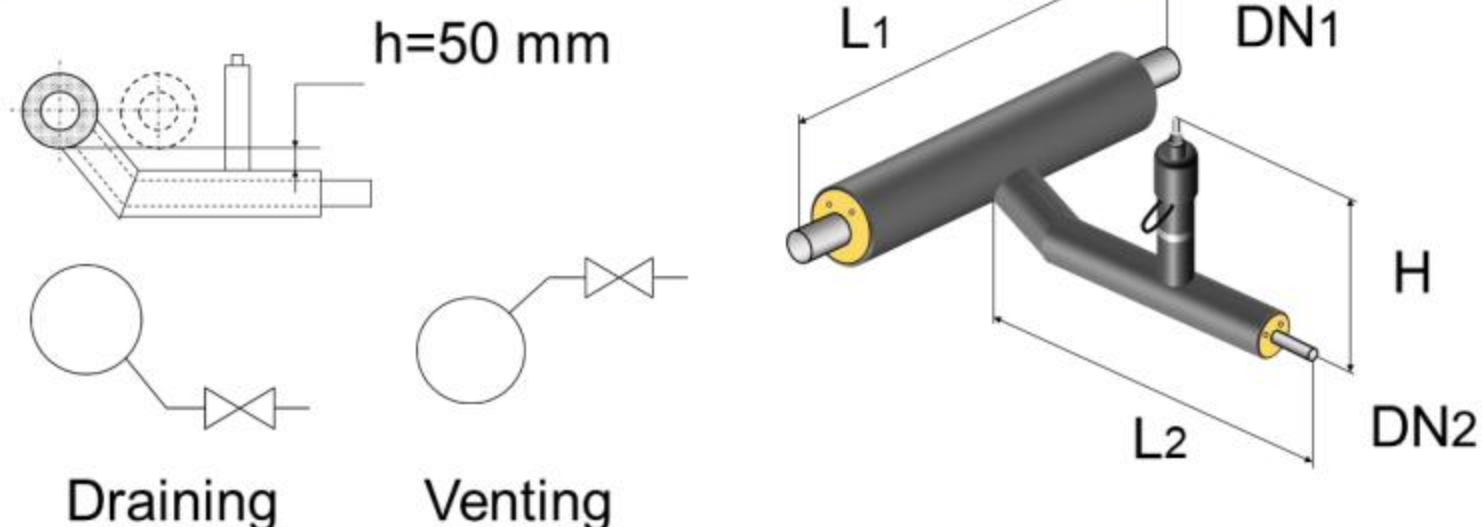

Series 1, 2, 3 and 4

Main pipe DN1	Branch pipe DN2	Key size, [mm]	H, [mm]	L1, [mm]	L2, [mm]
25	20	19	382	1 000	1 500
32	25	19	382	1 000	1 500
40	32	19	388	1 000	1 500
50	32	19	388	1 000	1 500
65	32	19	388	1 000	1 500
80	40	19	401	1 000	1 500
100	50	19	406	1 200	1 500
125	50	19	406	1 200	1 500
150	80	19	426	1 200	1 500
200	100	27	450	1 400	2 000
250	100	27	450	1 400	2 000
300	100	27	450	1 400	2 000
355	125	27	455	1 600	2 000
400	125	27	455	1 600	2 200
450	125	27	455	1 600	2 200
500	150	27	475	1 800	2 400
600	200	50	518	2 000	2 800
700	200	50	518	2 200	2 900
800	250	50	554	2 300	3 000

Upon request:

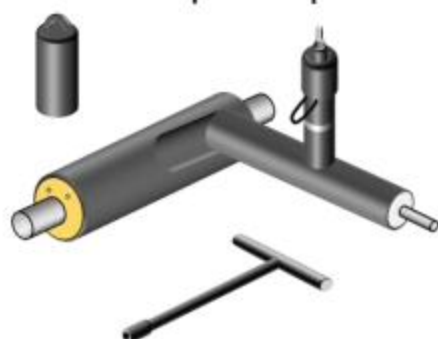

- higher stem height **H**;
- available in stainless steel top with PE protective cover;
- different air release sizes, than specified in table;
- with service valve for draining;
- different L1 and L2 lengths.

Preinsulated valve

3.4.1.

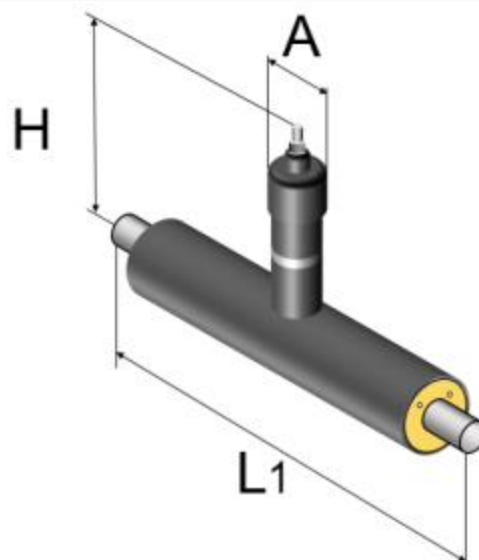

Series 1, 2, 3 and 4

Main pipe DN	L1 [mm]	H [mm]	A [mm]	Wrench size [mm]
25	1500	382	110	19
32	1500	388	110	19
40	1500	401	110	19
50	1500	406	110	19
65	1500	415	110	19
80	1500	426	110	19
100	1500	450	125	27
125	1500	455	125	27
150	1500	475	125	27
200	1500	517	160	50
250	1500	560	160	50
300	1800	610	160	50
350	1800	906	350	
400	2000	977	350	
500	custom	1056	350	
600	custom	1183	350	

Upon request:



- a higher stem height **H**;
- alarm wire take-out at the stem;
- T – shape key;
- removable PE cover at the top of the stem;
- Different L1 length.

Preinsulated valve with gear box

3.4.2.

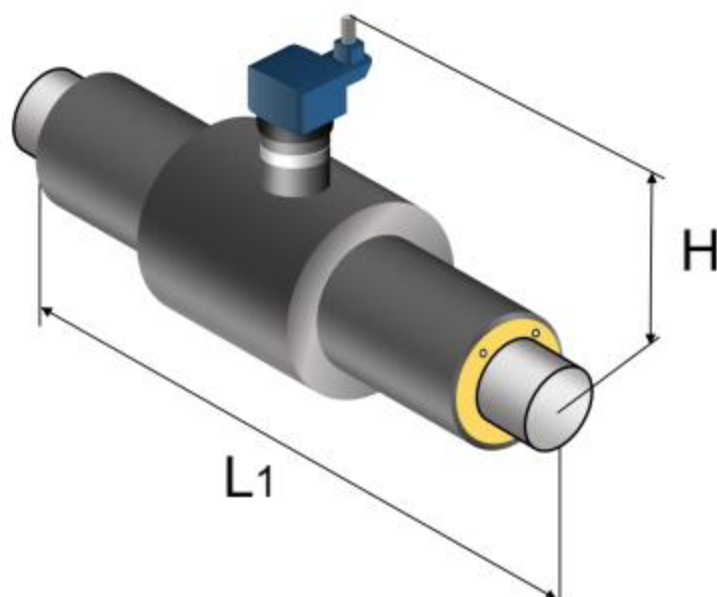

Series 1, 2, 3 and 4

Main pipe DN	L1, [mm]	H, [mm]	Wrench size, [mm]
200	1 500	713	19
250	1 500	765	19
300	1 800	805	19
350	2 000	830	19
400	2 000	909	19
500	2 200	947	19
600	2 400	1 020	19
700	2 500	1 243	19
800	3 000	1 332	19

Standard valves are with reduced bore, with size one step smaller than main valve.

Upon request:



- a higher stem height **H**;
- alarm wire take out;
- T – shaped key.

Valves with one (1) air vent/drain unit

3.4.3.

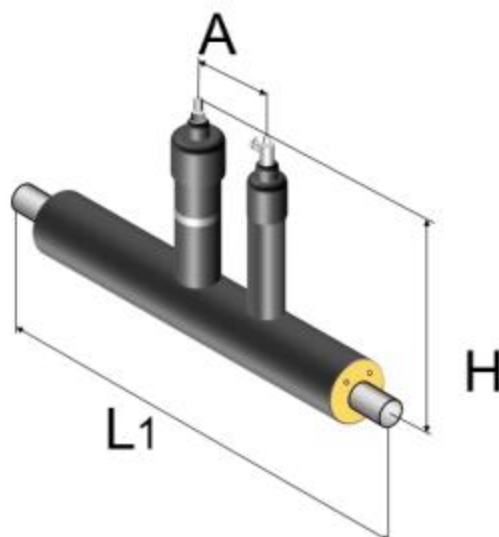

Series 1, 2, 3 and 4

Main pipe DN	Air-release valve DN	A, [mm]	Drainage valve DN	A, [mm]	L1, [mm]	H, [mm]
25	20	250	20	250	1 500	382
32	20	250	25	250	1 500	388
40	20	250	32	250	1 500	401
50	25	250	32	250	1 500	406
65	25	250	32	250	1 500	416
80	32	250	40	250	1 500	426
100	32	250	50	250	1 500	450
125	40	250	50	250	1 500	455
150	40	250	80	250	1 500	475
200	50	250	100	250	1 500	517
250	50	350	100	350	1 500	560
300	50	350	100	350	1 800	610

Upon request:



- different height H;
- with alarm wire takeout along main valve stem;
- T – shaped key;
- with PE valve cover;
- with stainless steel top cover;
- with different valve sizes.

Valves with two (2) air vent/drain units

3.4.4.

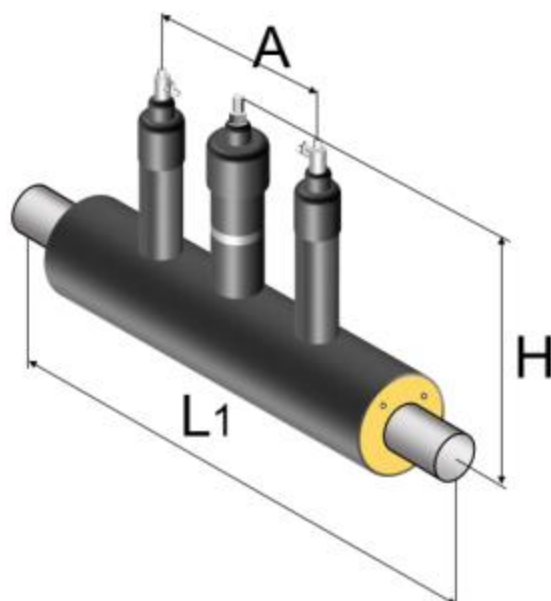

Series 1, 2, 3 and 4

Main pipe DN	Air-release valve		Drainage valve		L1, [mm]	H, [mm]
	DN	A, [mm]	DN	A, [mm]		
25	20	250	20	250	1 500	382
32	20	250	25	250	1 500	388
40	20	250	32	250	1 500	401
50	25	250	32	250	1 500	406
65	25	250	32	250	1 500	416
80	32	250	40	250	1 500	426
100	32	250	50	250	1 500	450
125	40	250	50	250	1 500	455
150	40	250	80	250	1 500	475
200	50	250	100	250	1 500	517
250	50	350	100	350	1 500	560
300	50	350	100	350	1 800	610

Upon request:



- different height H;
- with alarm wire takeout along main valve stem;
- T – shaped key;
- with PE valve cover;
- with stainless steel top cover;
- with different valve sizes.

Valve unit with two (2) air vent/drain units

3.4.5.

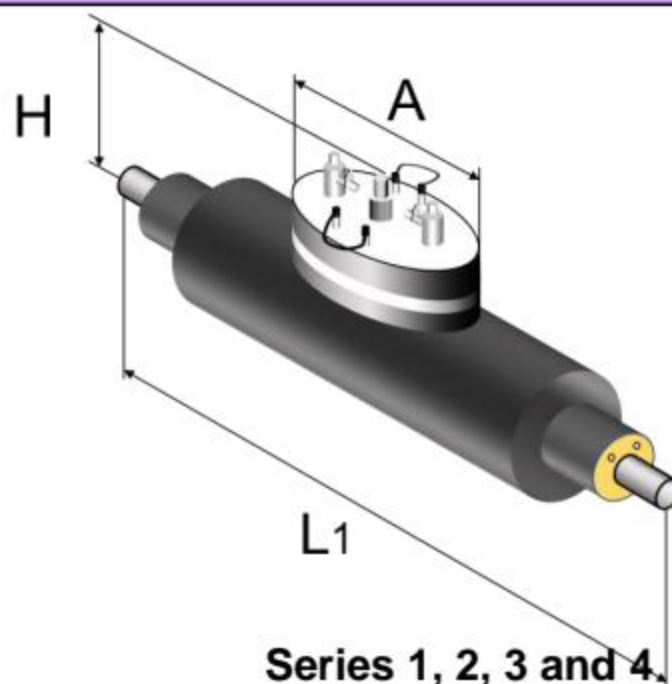

Main pipe DN	L1 [mm]	H [mm]	A [mm]	Wrench size [mm]	Air vent/drain DN
25	1500	382	610	19	25
32	1500	388	610	19	40
40	1500	401	610	19	50
50	1500	406	610	19	65
65	1500	415	610	19	
80	1500	426	610	19	
100	1500	450	610	27	
125	1500	455	610	27	
150	1500	475	610	27	
200	1500	517	610	50	
250	1500	560	810	50	
300	1800	610	810	50	
350	1800	906	810		
400	2000	977	1 010		
500	2200	1056	1 210		
600	2400	1183	1 310		

Top cover construction made of stainless steel. Includes alarm wire takeout.

Size over DN300 is equipped with hydraulic actuator (hydrox).

Upon request:



- different height H;
- T – shaped key;
- with PE valve cover.

POLIURS

v.1.2022

Preinsulated combination valve - Standard design 3.4.6.

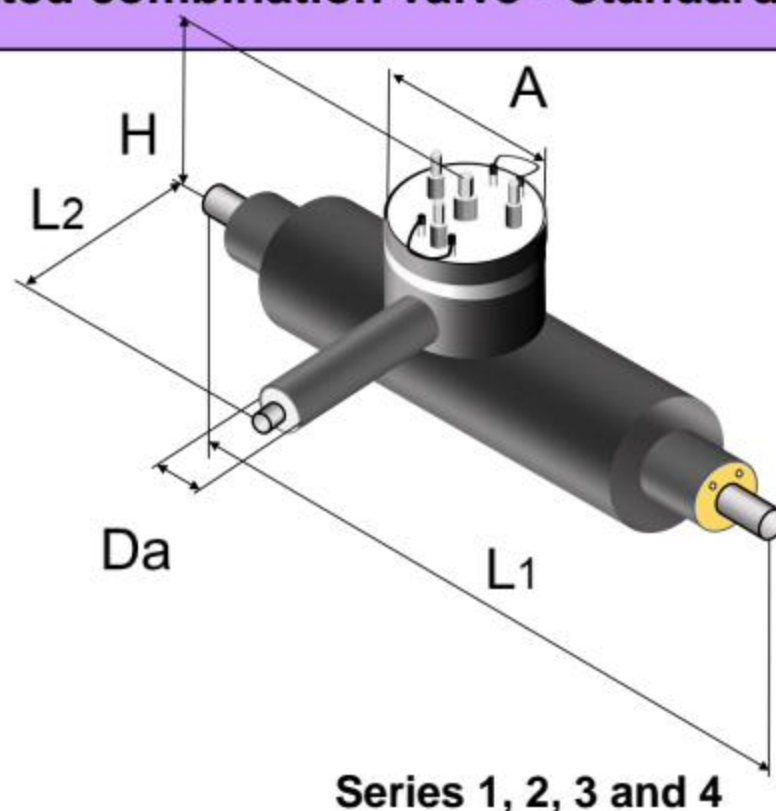

Main pipe DN	L1 [mm]	L2 [mm]	H [mm]	A [mm]	Wrench size [mm]	Da [mm]
100	1800	650	500	415	27	140
125	1800	650	500	415	27	140
150	1800	700	530	415	27	140
200	1800	700	560	415	50	140
250	1800	700	600	450	50	140
300	2100	750	700	450	50	140

Drain/air release pipe and tower construction are made of stainless steel.
Valves DN300 and greater provided with gear or hydrox actuator.

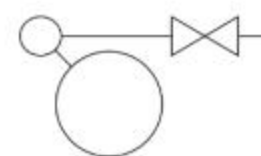
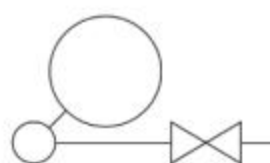
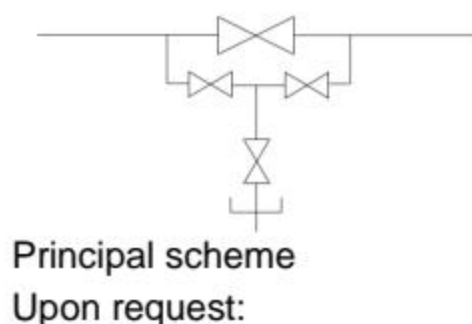

- different height H;
- T – shaped key;
- difference valve size.

Preinsulated combination valve – option design

3.4.7.

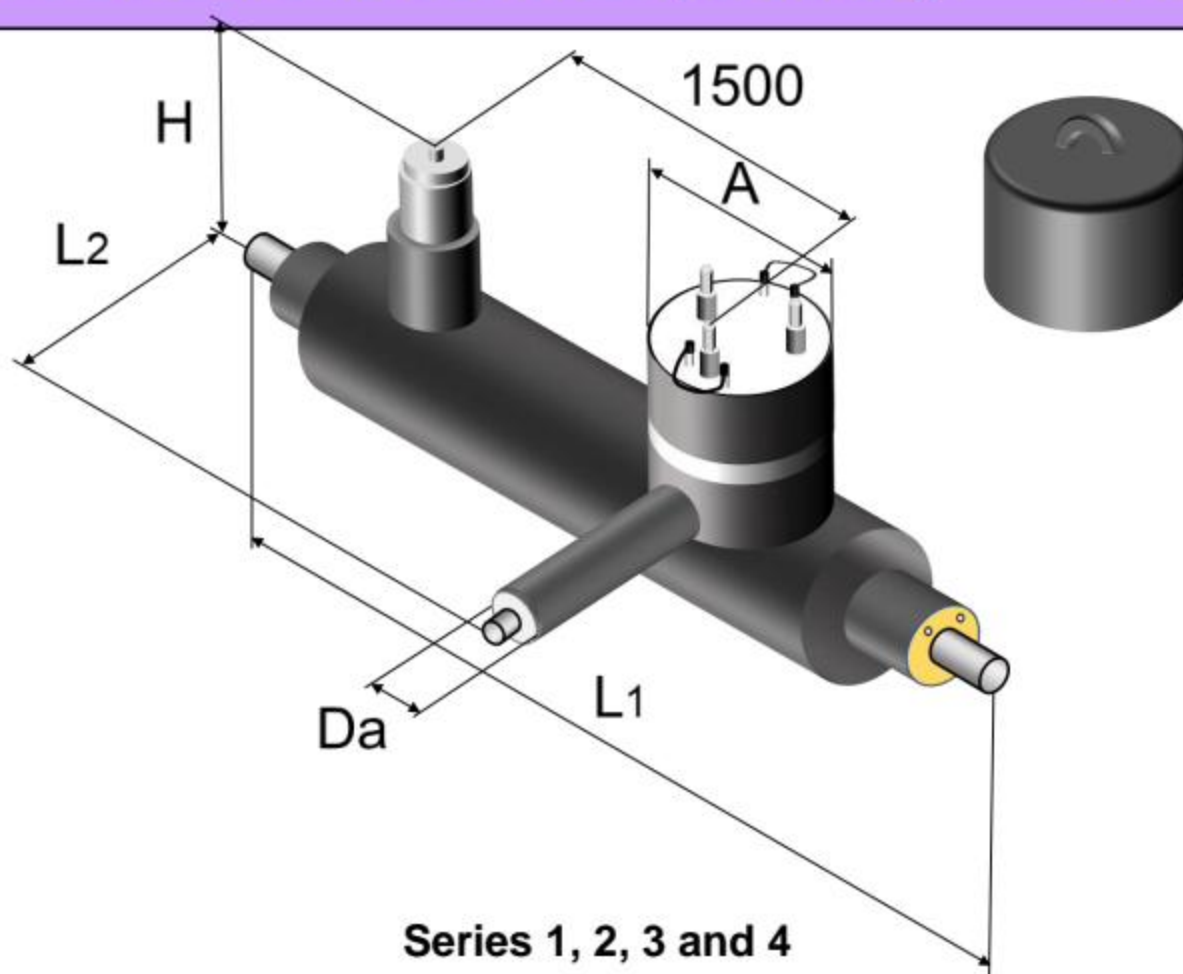

Main pipe DN	L1 [mm]	L2 [mm]	H [mm]	A [mm]	Bypass valve DN	Da [mm]
350	3200	800	940	450	50	140
400	3400	800	940	450	50	140
500	3600	900	1135	450	50	140

Drain/air release pipe and tower construction are made of stainless steel.

Valves DN300 and greater provided with gear or hydrox actuator.

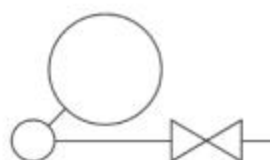
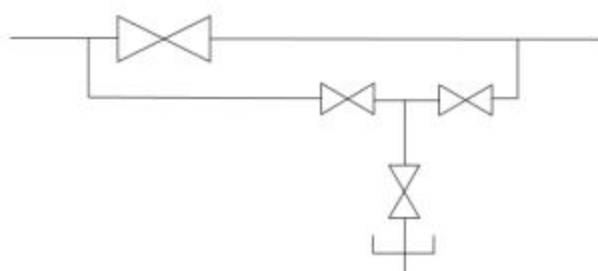

Draining

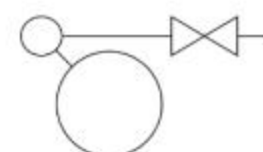

Venting

Upon request:



- different height H;
- T – shaped key;
- difference valve size.

POLIURS

v.1.2022

Preinsulated valve with bypass and outflow system 3.4.8.

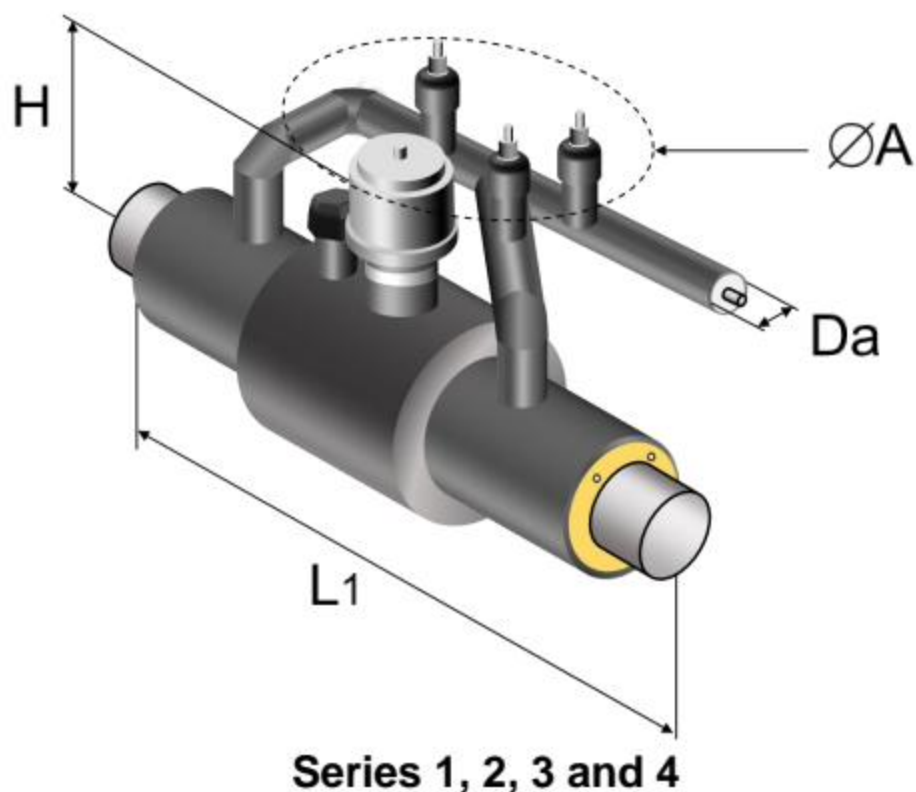

Main pipe DN	H [mm]	L1 [mm]	A [mm]	Bypass valve DN	Da [mm]
150	528	1500	600	25	125
200	535	2000	600	25	125
250	563	2000	600	25	125
300	614	2000	600	25	125
350	639	2000	800	25	125
400	691	2000	800	50	140
500	947	2500	800	50	140
600	1020	2500	800	50	140
700	1243	3000	1000	50 – 150	140 – 280

Alarm wires outtake in a screw cap.

*Upon request can be ordered different bypass DN.

Upon request:



- different height H;
- T – shaped key;
- with PE valve cover;
- different valve size.

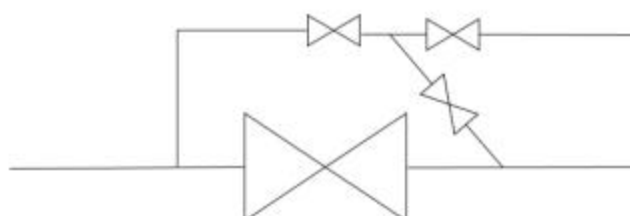

Preinsulated valve unit compact

3.4.9.

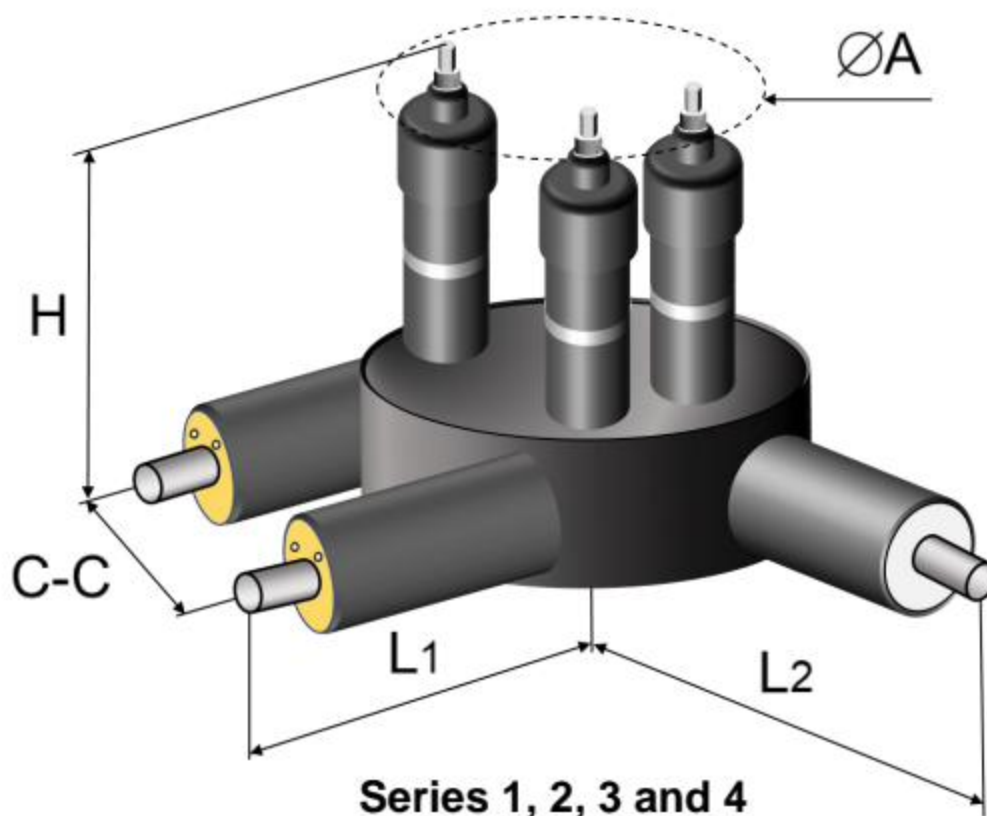

Main pipe DN	C-C [mm]	H [mm]	H min [mm]	A [mm]	L1 [mm]	L2 [mm]
25	300	382	190	357	600	600
32	380	388	200	407	670	650
40	385	401	200	425	670	670
50	455	406	210	479	780	700
65	500	415	210	517	810	730
80	530	426	225	537	820	758

It is possible to order different diameter of valve, height **H**, branch lengths **L1** and **L2**. Drain release pipe is made of stainless steel.

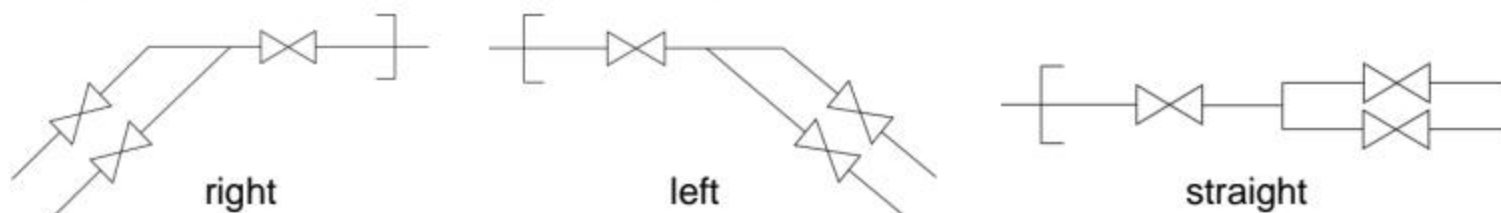

Upon request:



- different height **H**;
- T – shaped key;
- with PE valve cover;
- different valve size;
- different length **L1** and **L2**.

Preinsulated fixed anchors

3.5.1.

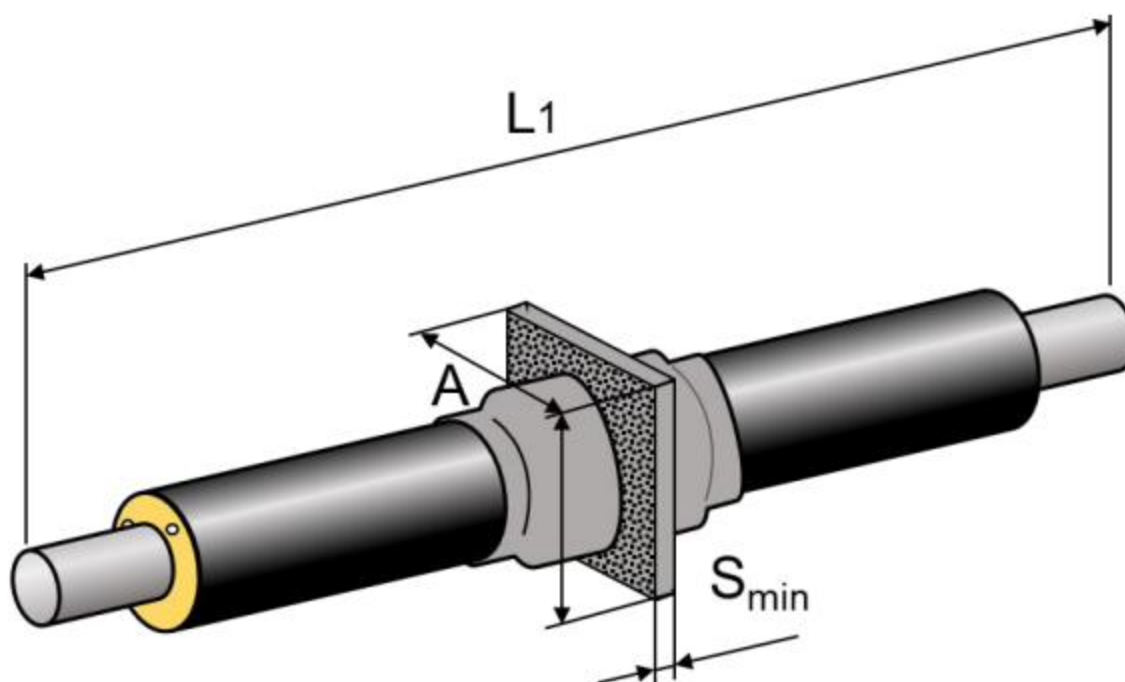

Series 1, 2, 3 and 4

Main pipe DN	Max load kN $\Delta T = 60^{\circ}\text{C}$	A [mm]	S [mm]	Pressure area [cm ²]	L1 [mm]
25	38	200	25	191	2 000
32	49	220	25	243	2 000
40	56	220	25	243	2 000
50	78	240	25	289	2 000
65	100	280	25	452	2 000
80	129	300	30	392	2 000
100	187	350	30	565	2 000
125	230	400	30	765	2 000
150	310	450	30	875	2 300
200	455	550	35	1385	2 300
250	630	650	40	1730	2 300
300	840	700	40	1885	2 300
400	1200	850	40	2560	2 500
500	1500	1000	65	4000	2 500
600	2000	1200	65	6200	3 000

Anchor plate next to working pipe is strengthened with additional steady ribs.

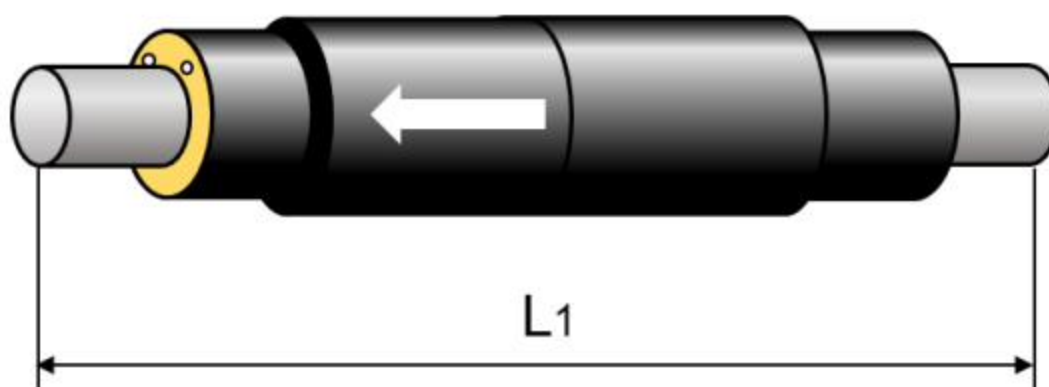

Series 1, 2, 3 and 4

Main pipe DN	Length of max compensation [mm]	L1 [mm]
40	100	2200
50	100	2200
65	100	2200
80	100	2200
100	125	2200
125	125	2200
150	125	2200
200	150	2200
250	150	2200
300	150	2200
350	150	2200
400	150	2500
450	150	2500
500	150	2800
600	150	2800

Water flow is marked with an arrow.

Axial displacement can be changed upon a request.

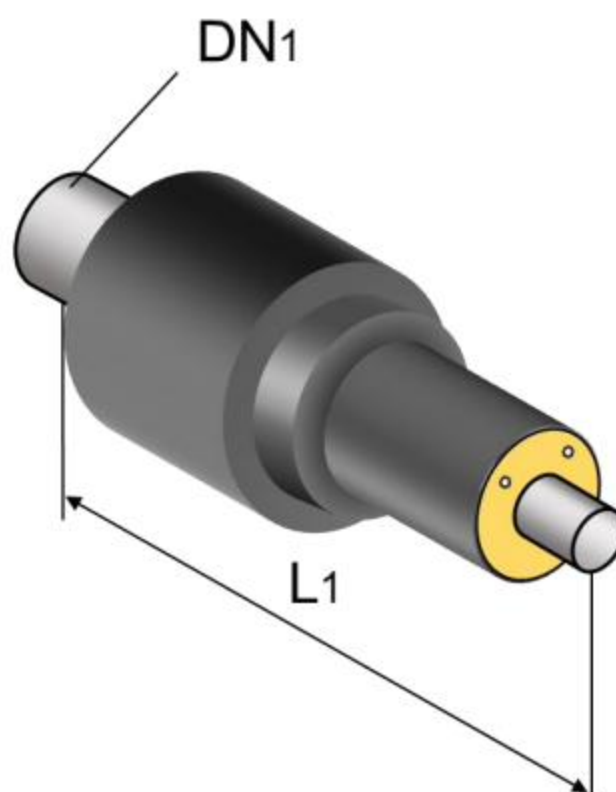

Series 1, 2, 3 and 4

Main pipe DN1	L1 [mm]
25 – 300	900
350 – 500	1100
600 – 800	1300

Can be ordered with dimensions greater than DN800 and reduction between 1 – 3 dimension levels.

On request: reducer can be produced as one product together with perpendicular or parallel T-branches.



Pipes
4.1.1. – 4.1.5.



Bends
4.2.1. – 4.2.4.



T-pieces
4.3.1. – 4.3.3.



Transition pipes
4.3.4. – 4.3.5.



Valves
4.4.1.



**Valves with
air vent/drain units**
4.4.2.



Combination valves
4.4.3. – 4.4.4.



Air vent/drain units
4.4.5.



Diameter reducers
4.5.1.

Preinsulated twin pipes

4.1.1.

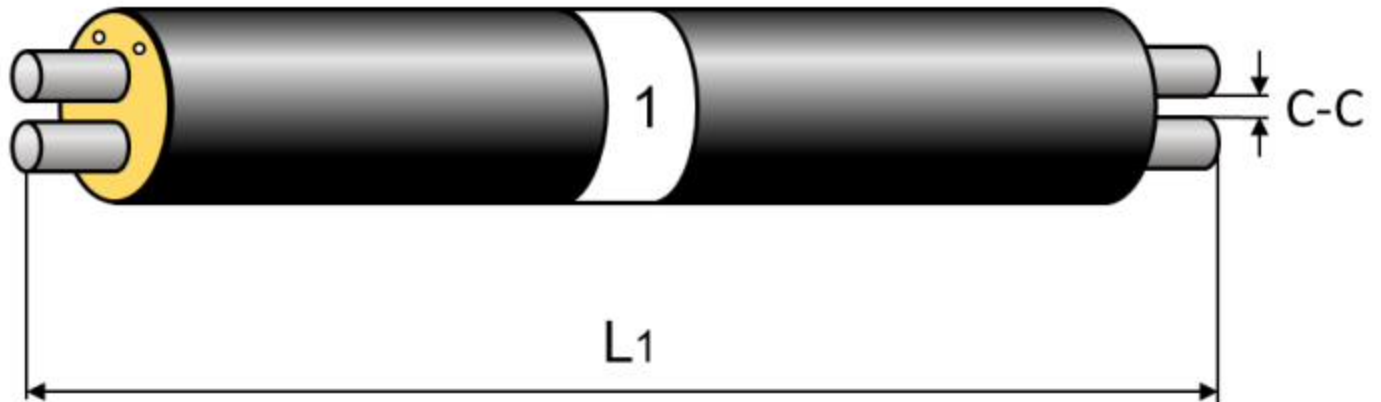

Series 1

Main pipe DN	PE casing pipe [mm]	Weight [kg/m]	C-C [mm]	Water content [l/m]	Transfer capacity $\Delta T = 50\text{ }^{\circ}\text{C}$ [kW]
20	125	4,9	19	0,8	65
25	140	7,1	19	1,2	100
32	160	9,1	19	2,2	180
40	160	9,6	19	3,0	230
50	200	13,1	20	4,6	370
65	225	16,5	20	7,0	700
80	250	20,7	25	10,6	1 000
100	315	30,7	25	18,0	1 800
125	400	41,5	30	27,6	3 300
150	450	51,0	40	40,4	5 000
200	560	76,0	45	69,4	10 000

Pipe length **L1** can be ordered 6; 12; 16; 18 m.

Material of service pipe - steel. On request - copper or stainless steel.

Material of casing pipe - high density polyethylene (PE100).

Preinsulated twin pipes

4.1.2.

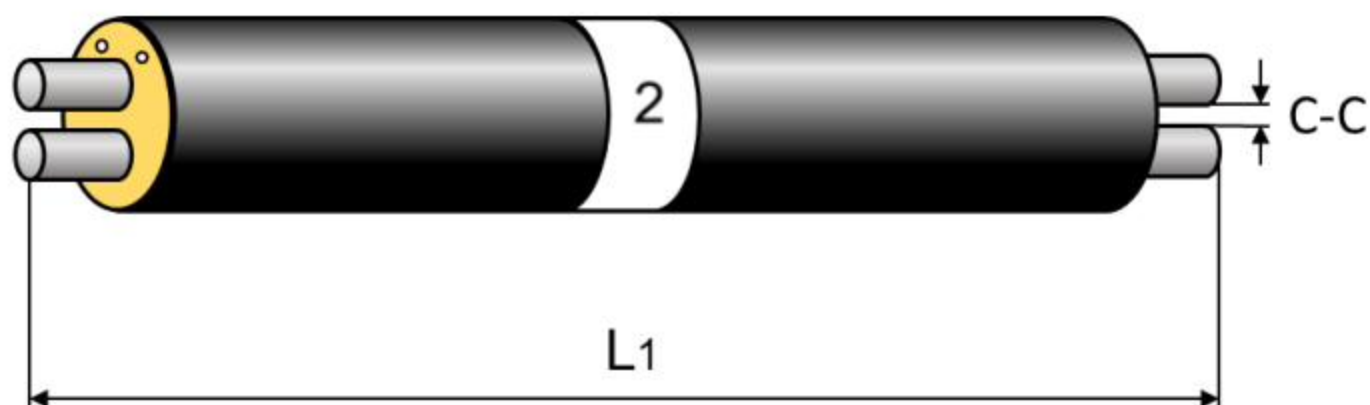

Series 2

Main pipe DN	PE casing pipe [mm]	Weight [kg/m]	C-C [mm]	Water content [l/m]	Transfer capacity $\Delta T = 50\text{ }^{\circ}\text{C}$ [kW]
20	140	6,1	19	0,8	65
25	160	7,8	19	1,2	100
32	180	9,9	19	2,2	180
40	180	10,3	19	3,0	230
50	225	14,0	20	4,6	370
65	250	17,6	20	7,0	700
80	280	22,8	25	10,6	1 000
100	355	33,9	25	18,0	1 800
125	450	46,3	30	27,6	3 300
150	500	56,5	40	40,4	5 000
200	630	82,9	45	69,4	10 000

Pipe length **L1** can be ordered 6; 12; 16; 18 m.

Material of service pipe - steel. On request - copper or stainless steel.

Material of casing pipe - high density polyethylene (PE100).

Preinsulated twin pipes

4.1.3.

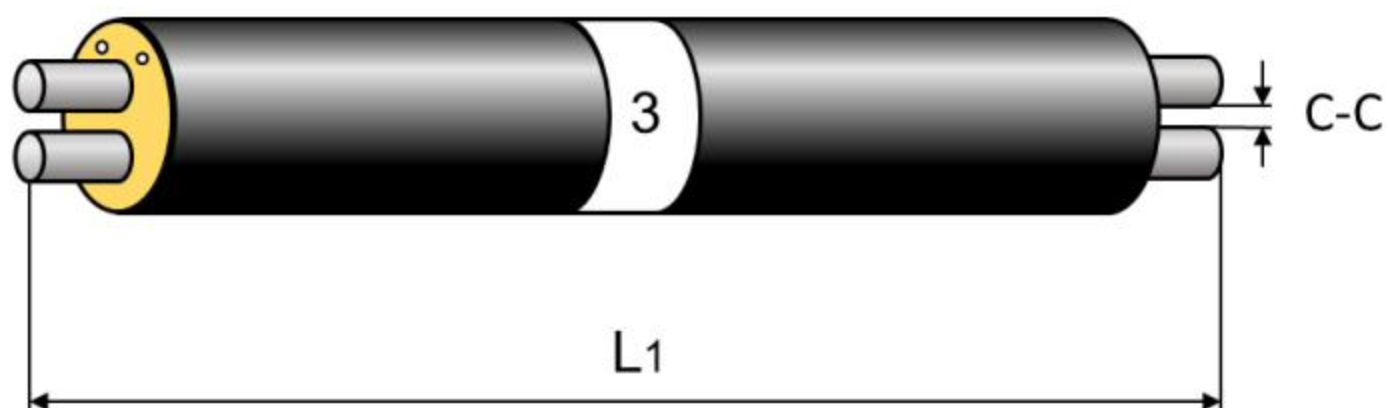

Series 3

Main pipe DN	PE casing pipe [mm]	Weight [kg/m]	C-C [mm]	Water content [l/m]	Transfer capacity $\Delta T = 50\text{ }^{\circ}\text{C}$ [kW]
20	160	6,74	19	0,8	65
25	180	8,5	19	1,2	100
32	200	10,6	19	2,2	180
40	200	11,1	19	3,0	230
50	250	15,1	20	4,6	370
65	280	19,7	20	7,0	700
80	315	24,9	25	10,6	1 000
100	400	37,8	25	18,0	1 800
125	500	51,8	30	27,6	3 300
150	560	63,7	40	40,4	5 000
200	710	91,2	45	69,4	10 000

Pipe length **L1** can be ordered 6; 12; 16; 18 m.

Material of service pipe - steel. On request - copper or stainless steel.

Material of casing pipe - high density polyethylene (PE100).

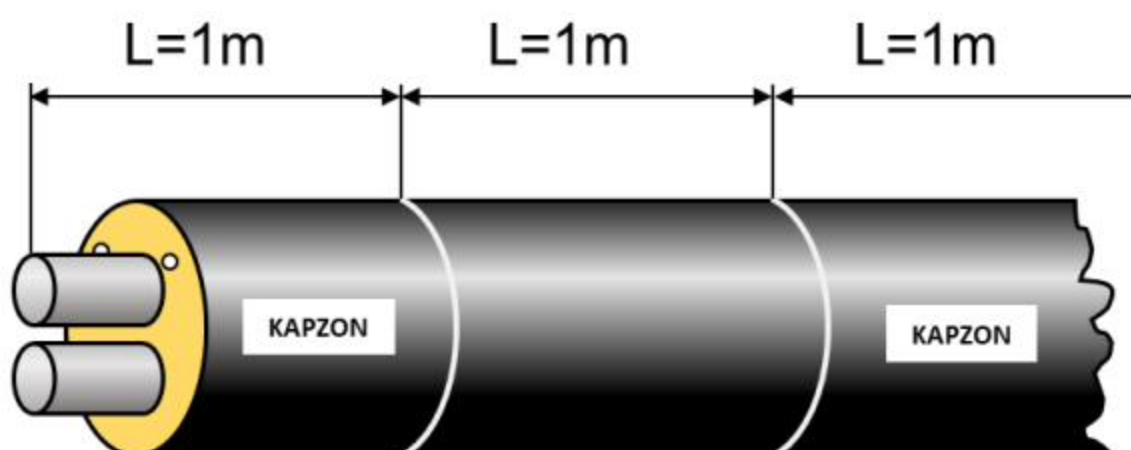

Series 1, 2 and 3

Steel service pipe is covered by a plastic foil every second meter along the entire pipe length. This arrangement allows easy removal of the foam from the steel in the sections which are indicated on the outside casing pipe. Whole lengths or parts of pipes cut-to-length can be installed at any place.

L1 segments can be ordered on 6; 12; 16; 18 m long pipes.

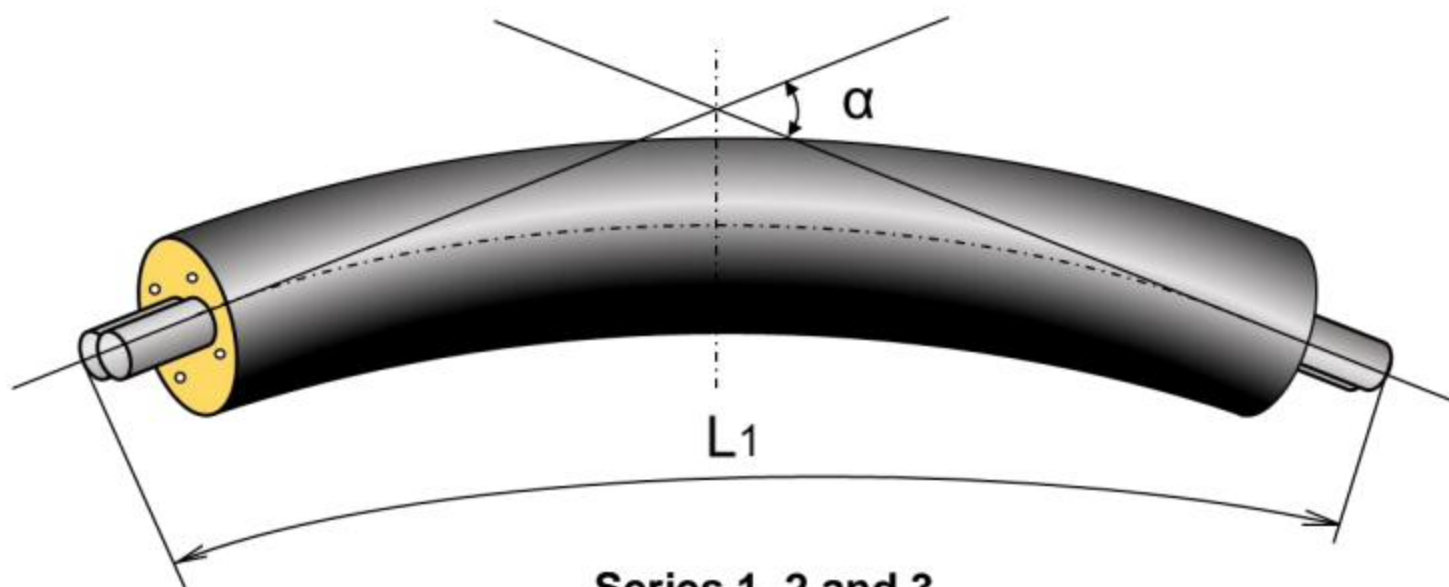

Main pipe DN	PE casing pipe [mm]	Max deflection angle on L1=12m	Max deflection angle on L1=16m
25 – 50	140 – 250	45°	45°
65 – 80	225 – 315	45°	45°
100	315 – 400	35°	35°
125 – 150	400 – 560	30°	30°
200	560 – 710	20°	20°

Allowable accuracy: DN 25 – 80 mm +/- 2°

DN 100 – 200 mm +/- 1°

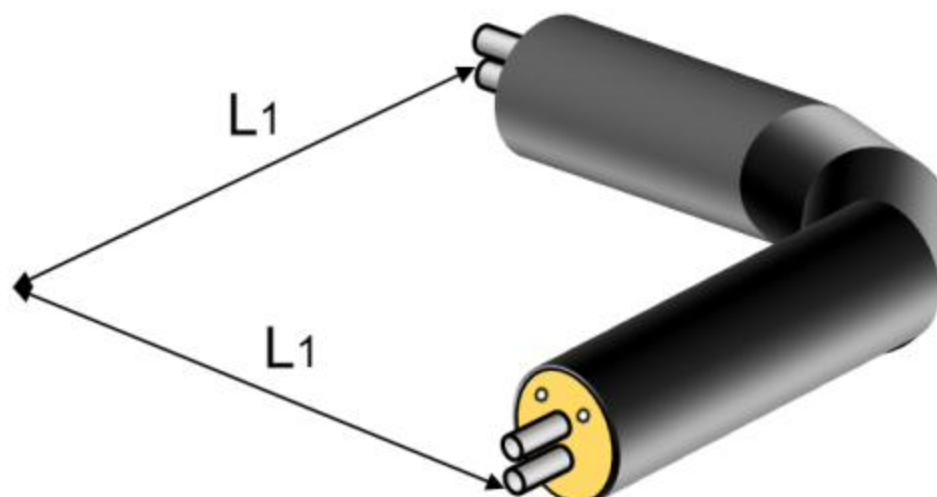

Series 1, 2 and 3

Main pipe DN	PE casing pipe [mm]			L1 [mm]
	Series 1	Series 2	Series 3	
20	125	140	160	1000
25	140	160	180	1000
32	160	180	200	1000
40	160	180	200	1000
50	200	225	250	1000
65	225	250	280	1000
80	250	280	315	1000
100	315	355	400	1000
125	400	450	500	1000
150	450	500	560	1000
200	560	630	710	1000

Angle α in a standard bends is 90° .

The bends with degrees from 5° to 90° and leg length up to 10,0 m can be made upon a request.

Preinsulated twin pipe vertical bends

4.2.2.

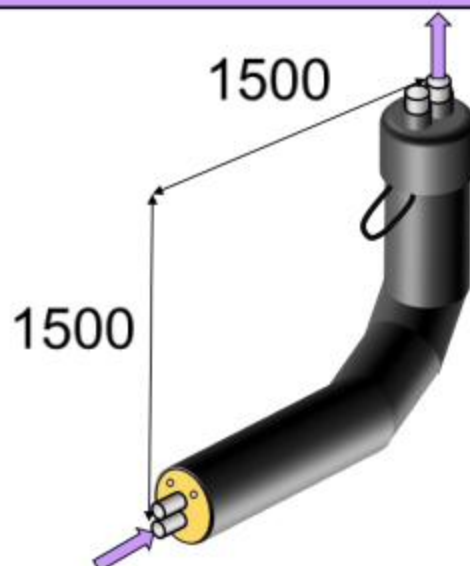

Series 1, 2 and 3

Main pipe DN	PE casing pipe [mm]		
	Series 1	Series 2	Series 3
20	125	140	160
25	140	160	180
32	160	180	200
40	160	180	200
50	200	225	250
65	225	250	280
80	250	280	315
100	315	355	400
125	400	450	500
150	450	500	560
200	560	630	710

Different leg length up to 10,0 m can be made on request.

Can be ordered without an end cap.



Optional right



Optional left

Connection bend for facade installation

4.2.3.

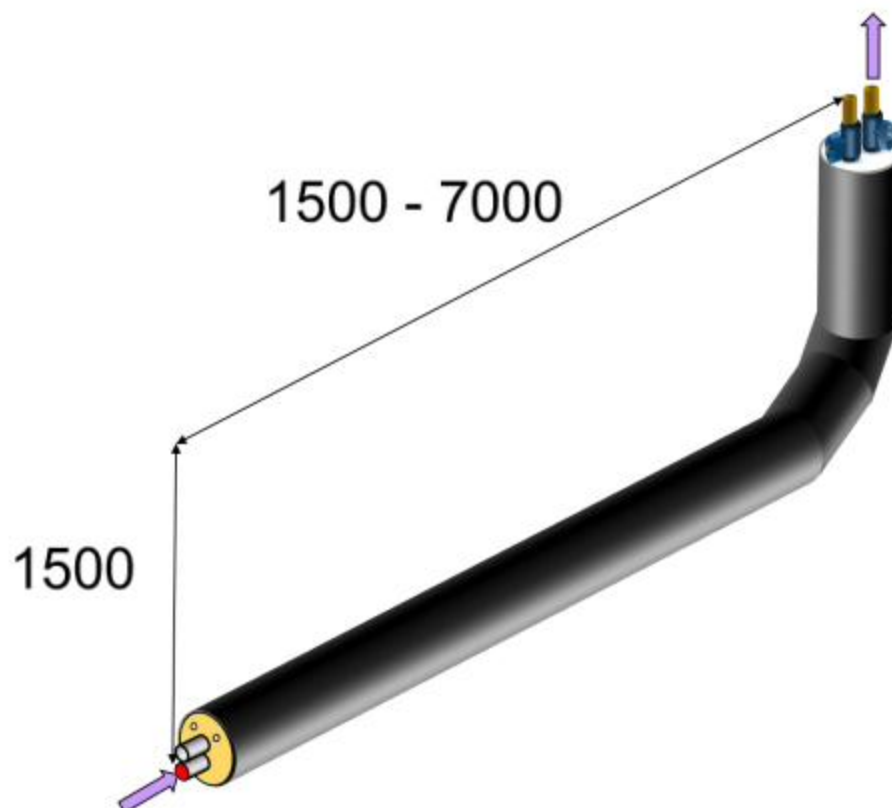

Series 1, 2 and 3

Main pipe DN	PE casing pipe [mm]
20	125 – 160
25	140 – 180

Connector bend for facade installation is supplied with extended neck valves and a copper connection pipe. Flow valve is marked in red. The connection bend can be ordered with up to 7m leg length, custom angles, dimensions and with left or right flow handle position.

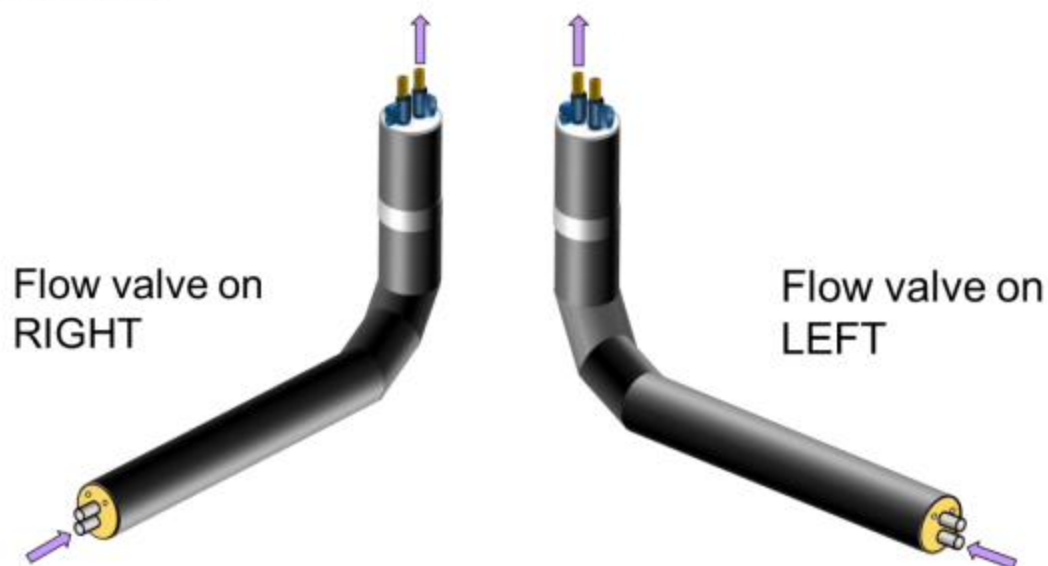

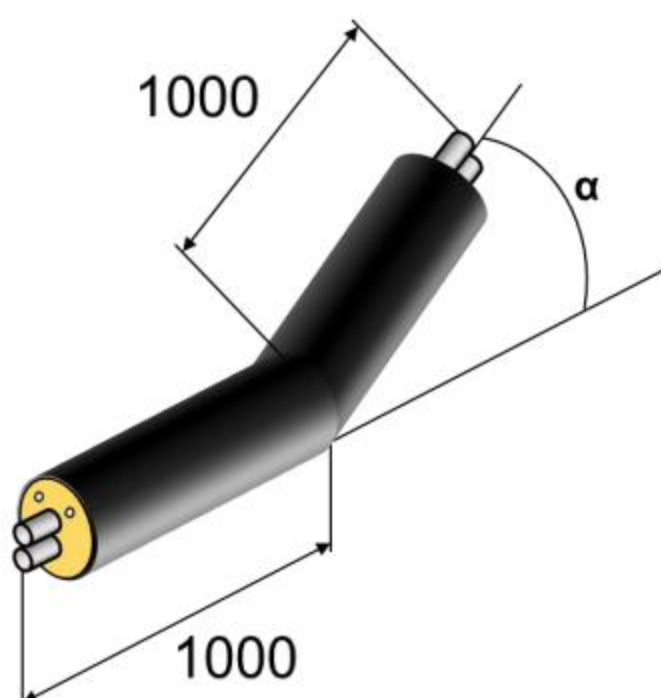

Series 1, 2 and 3

Main pipe DN	PE casing pipe [mm]		
	Series 1	Series 2	Series 3
20	125	140	160
25	140	160	180
32	160	180	200
40	160	180	200
50	200	225	250
65	225	250	280
80	250	280	315
100	315	355	400
125	400	450	500
150	450	500	560
200	560	630	710

Different leg length up to 10,0 m can be made on request.

Can be ordered with an angle up to 90 deg.

Preinsulated twin pipe T-branches

4.3.1.

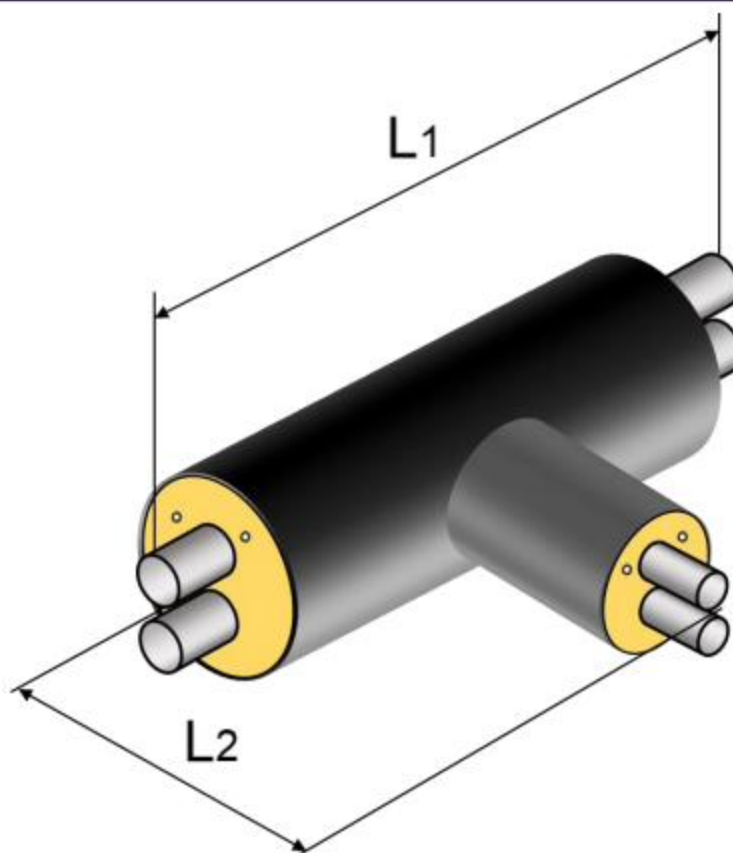

Series 1, 2 and 3

Main pipe DN	Branch pipe DN	Main pipe		PE casing pipe [mm]			
		L1 [mm]	L2 [mm]	DN	Series 1	Series 2	Series 3
25 – 200	20 – 100	1200	700	25	140	160	180
125 – 200	125 – 150	1500	900	32	160	180	200
200	200	1500	900	40	160	180	200
				50	200	225	250
				65	225	250	280
				80	250	280	315
				100	315	355	400
				125	400	450	500
				150	450	500	560
				200	560	630	710

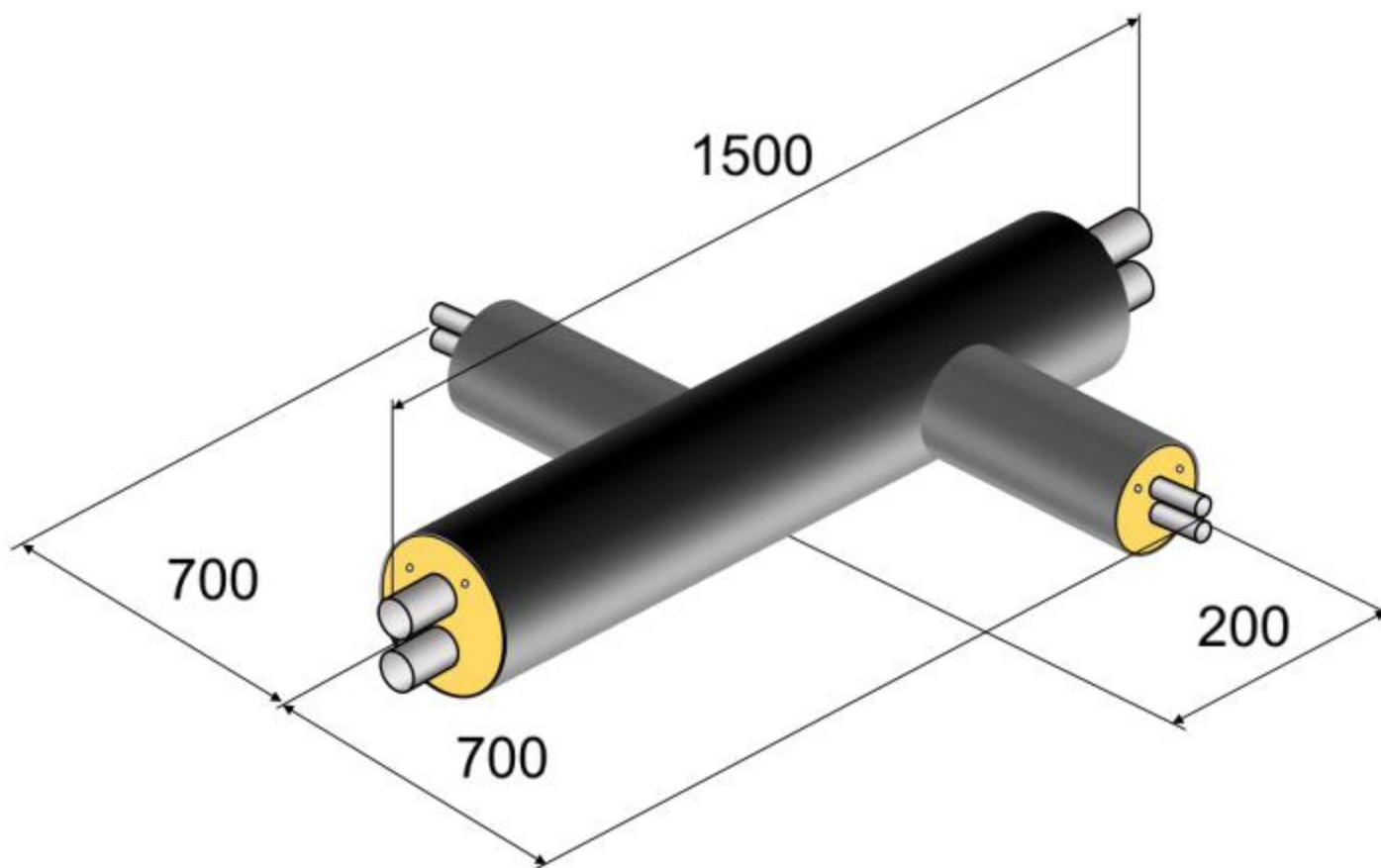

Series 1, 2 and 3

Main pipe DN	Branch pipe DN
25 - 200	20 - 65

Diameter of branch cannot be greater than diameter of main pipe.



Preinsulated Twin T-piece

4.3.3.

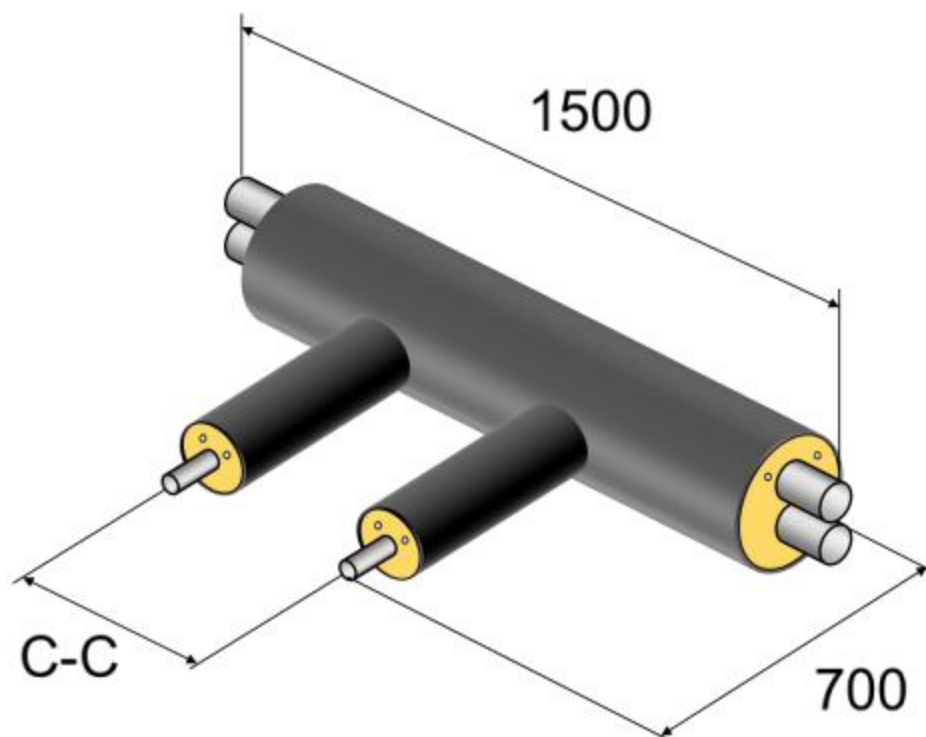

Series 1, 2 and 3

Main pipe DN	Branch pipe DN	C-C [mm]
25 - 200	20	310
	25	310
	32	325
	40	325
	50	340
	65	360
	80	380

Branch pipe is insulated in series 2.

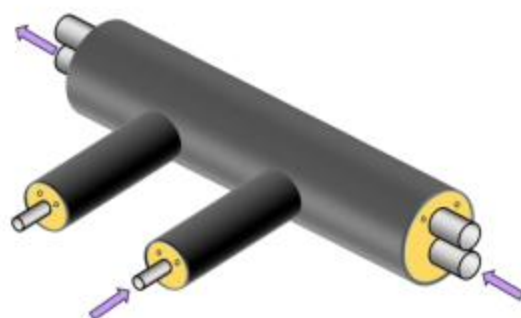

Right

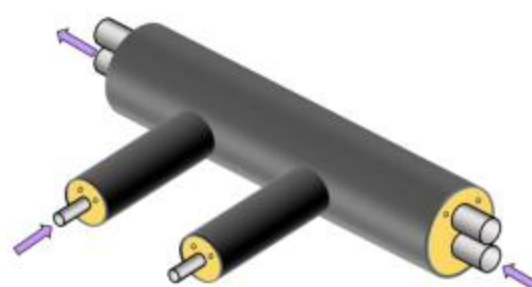

Left

Preinsulated pipes F-transition

4.3.4.

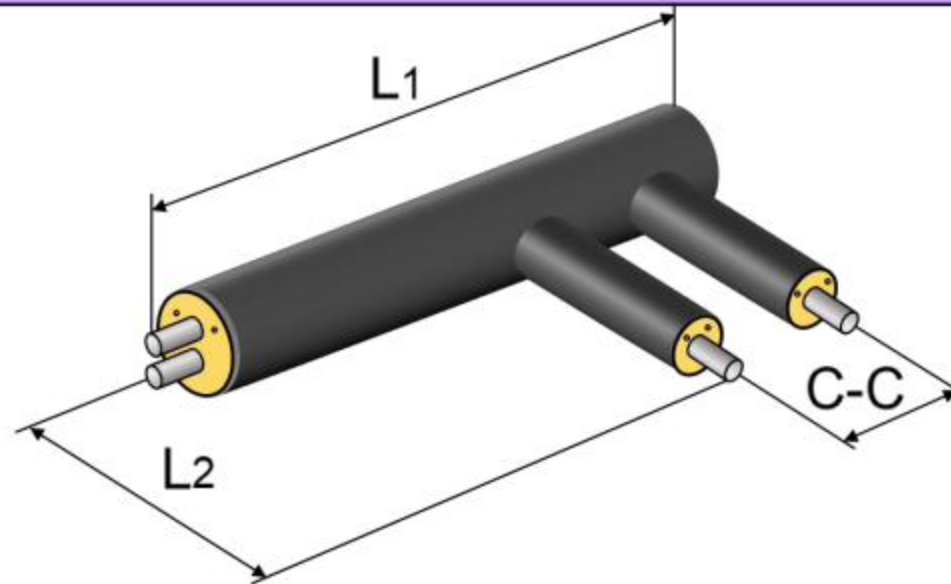

Series 1, 2 and 3

Main pipe DN	C-C [mm]	L1 [mm]	L2 [mm]
25	265	1586	1000
32	280	1593	1000
40	280	1610	1000
50	305	1630	1000
65	330	1603	700
80	360	1620	700
100	435	1740	700
125	530	1780	700
150	580	1835	700
200	710	2015	900

Two (2) different transformation types are possible:

- left hand flow with flow pipe under;
- right hand flow with flow pipe under (flow pipe is marked in dark color).

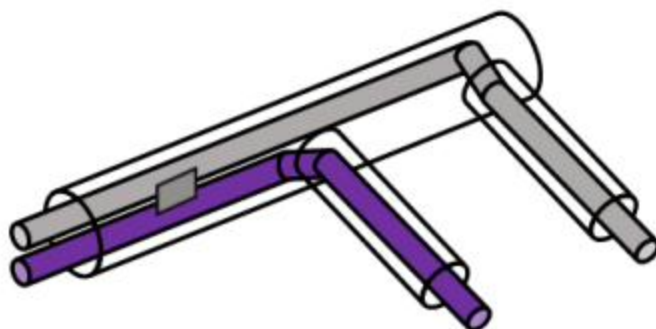

Left hand flow

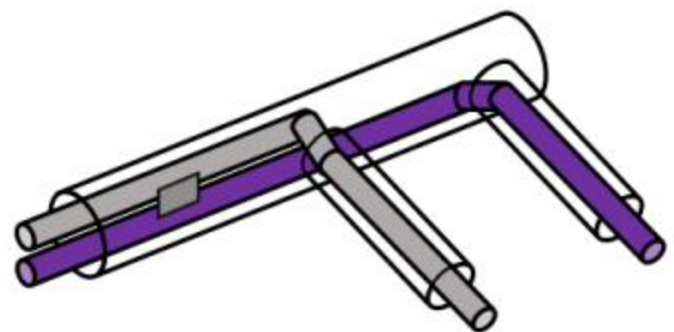

Right hand flow

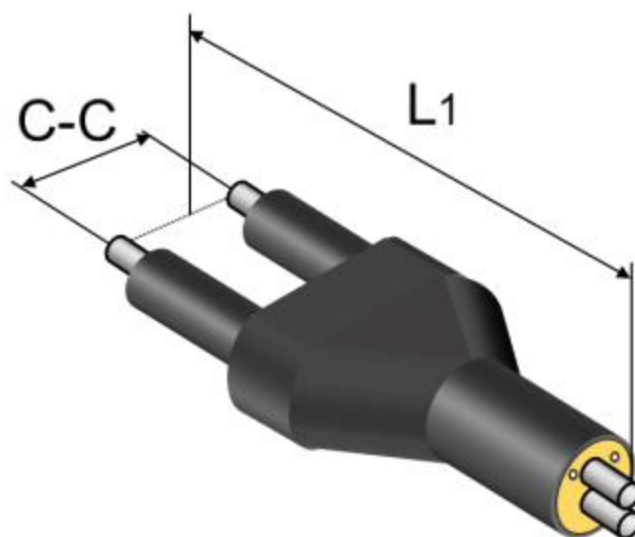

Series 1, 2 and 3

Main pipe DN	C-C [mm]	L1 [mm]
25	265	1973
32	280	1971
40	280	1971
50	305	1966
65	330	1962
80	360	1955
100	435	1955
125	530	2500
150	580	2500
200	710	2500

Two (2) different transformation executions are possible:

- from two pipe system to double pipe system;
- from double pipe system to two pipe system.

Can order pipes with left hand flow and right-hand flow. Flow pipe is at the bottom in double pipe in both executions. Flow pipe is marked in dark color.

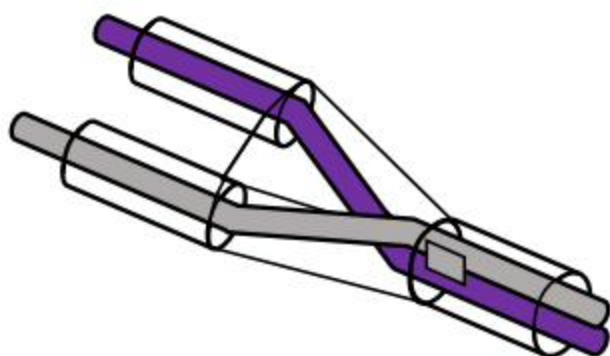

Left hand flow

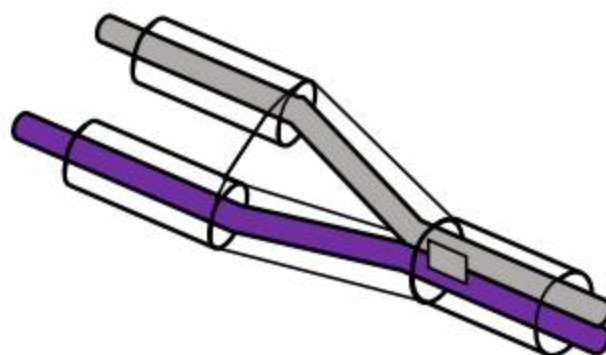

Right hand flow

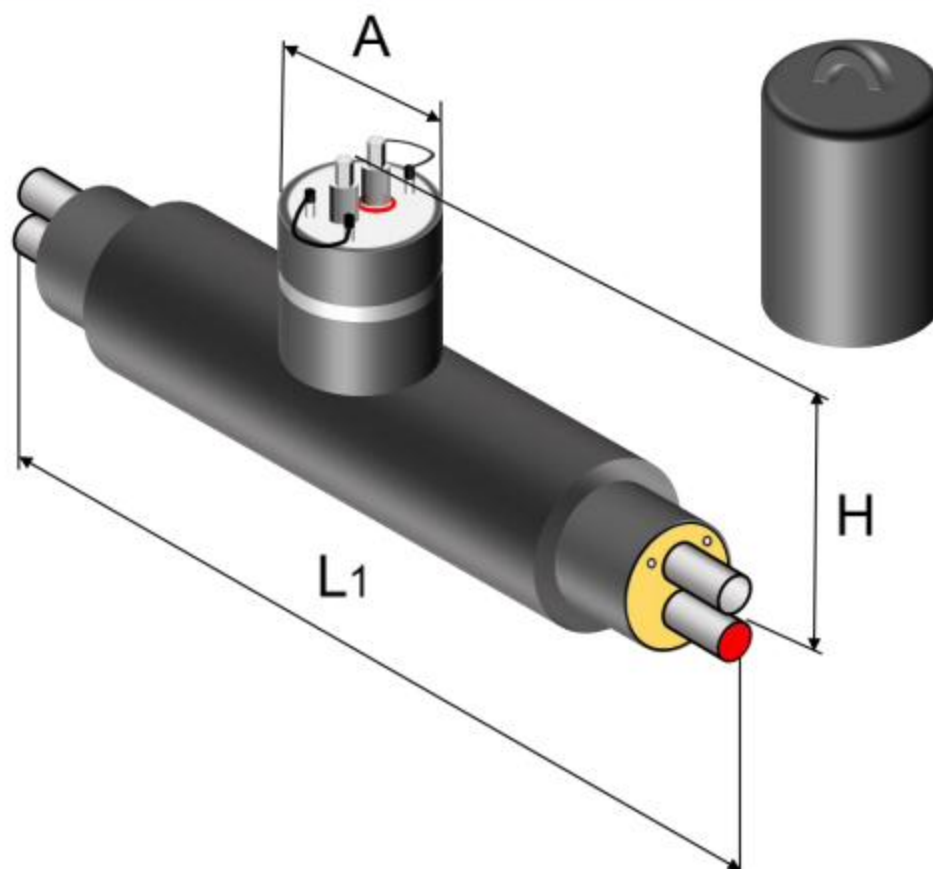

Series 1, 2 and 3

Main pipe DN	L1 [mm]	H [mm]	A [mm]	Wrench size [mm]
25	1800	409	150	19
32	1800	422	170	19
40	1800	435	170	19
50	1800	451	190	19
65	1800	463	190	19
80	2600	483	190	19
100	2800	519	235	27
125	3200	540	295	27
150	3400	578	295	27
200	3600	652	295	50

The construction of ball valve control axis provides possibility to open and close the valve from above-ground using T-shaped end key.

It is possible to order different height of the valve **H**.

Tower construction in stainless steel.

Preinsulated twin valves with air vent/drain units

4.4.2.

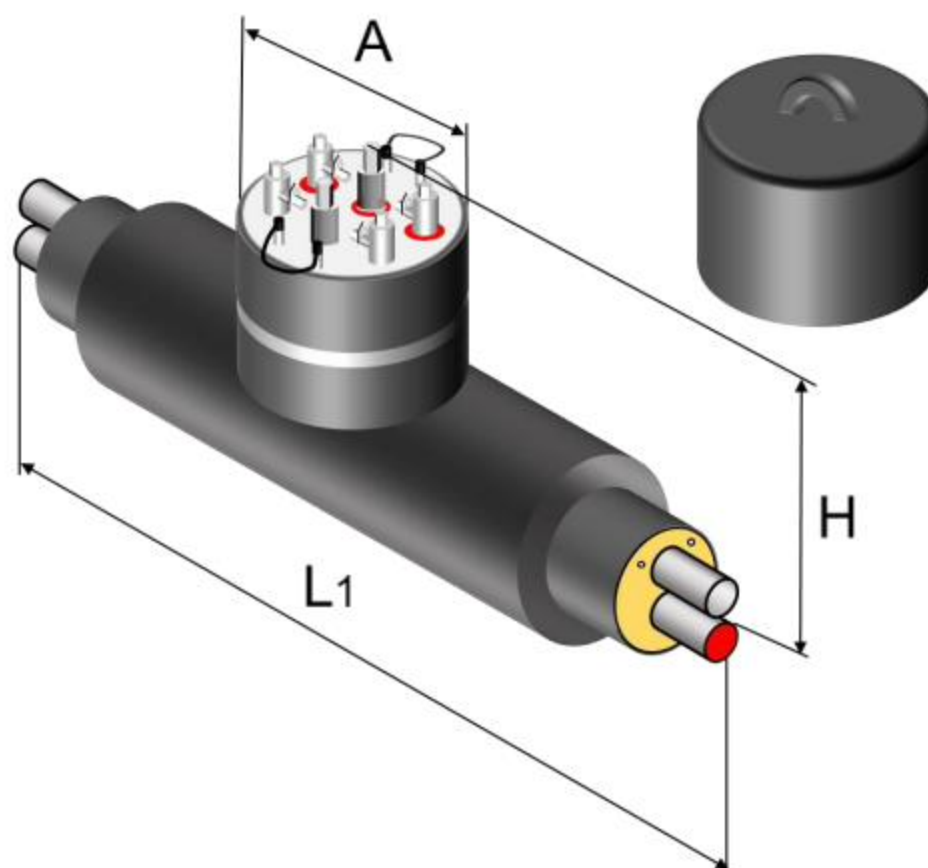

Series 1, 2 and 3

Main pipe DN	L1 [mm]	H [mm]	A [mm]	Wrench size [mm]
25	2300	409	295	19
32	2300	422	295	19
40	2300	435	295	19
50	2400	451	295	19
65	2400	463	295	19
80	2600	483	295	19
100	2800	519	295	27
125	3200	540	340	27
150	3400	578	415	27
200	3600	652	450	50

Tower construction in stainless steel.

Preinsulated combination valve

4.4.3.

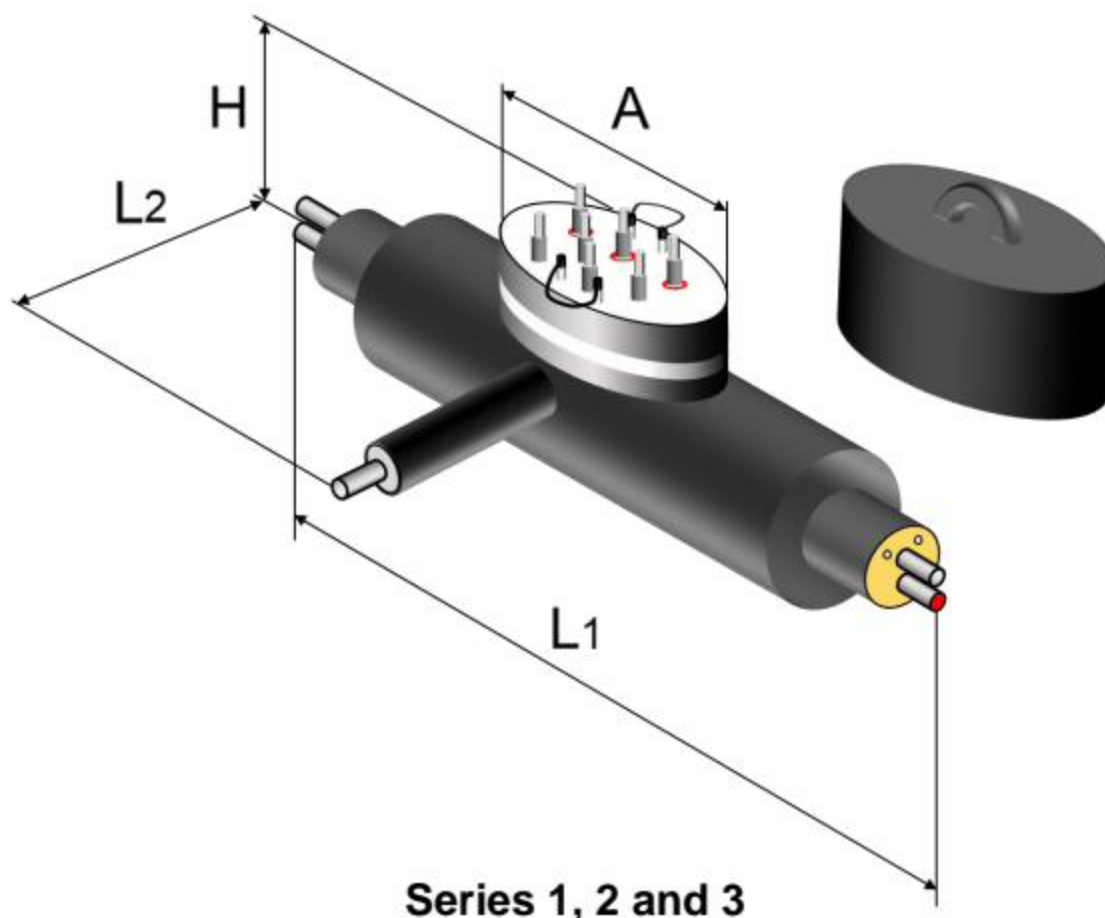

Main pipe DN	L1 [mm]	L2 [mm]	H [mm]	A [mm]	Wrench size [mm]
25	2300	700	409	700	19
32	2300	700	422	700	19
40	2300	700	435	700	19
50	2400	700	451	700	19
65	2400	700	463	700	19
80	2600	700	483	700	19
100	2800	700	519	700	27
125	3200	700	540	700	27
150	3400	700	578	700	27
200	3600	900	652	900	50

Tower construction in stainless steel.

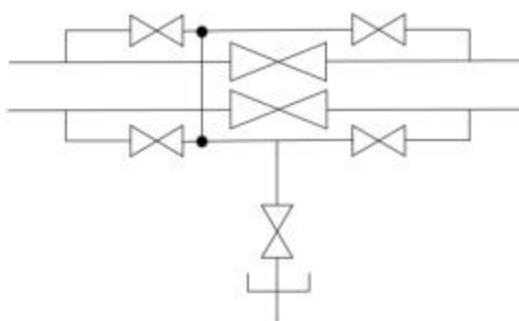

Preinsulated compact valve

4.4.4.

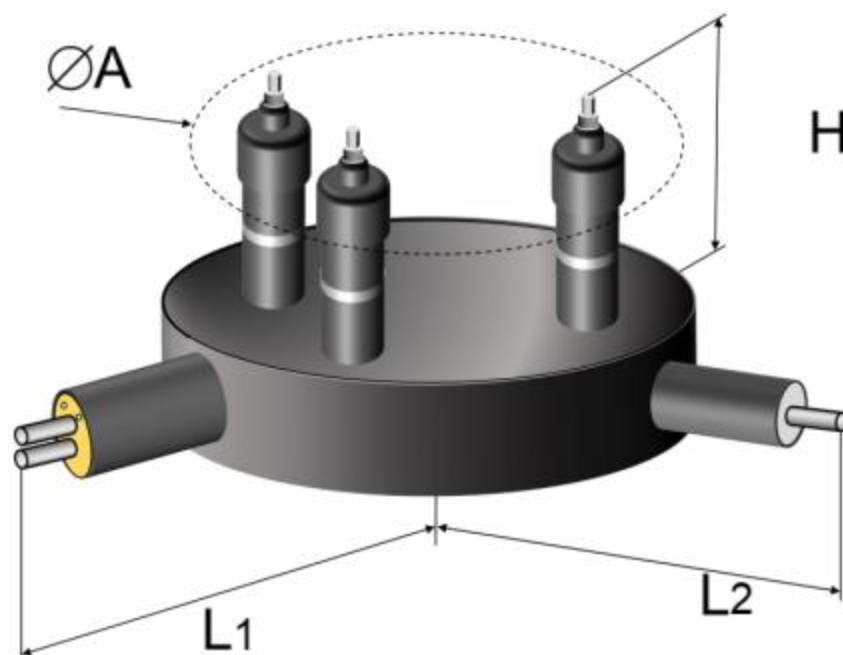

Series 1, 2 and 3

Main pipe DN	H [mm]	A [mm]	L1 [mm]	L2 [mm]
25	382	445	850	520
32	388	465	965	560
40	401	490	885	570
50	406	510	1055	610

Drain release pipe is made of stainless steel.

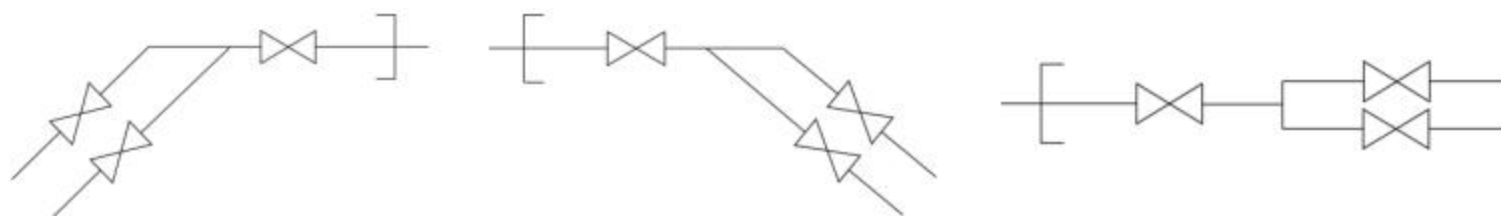

right

left

straight

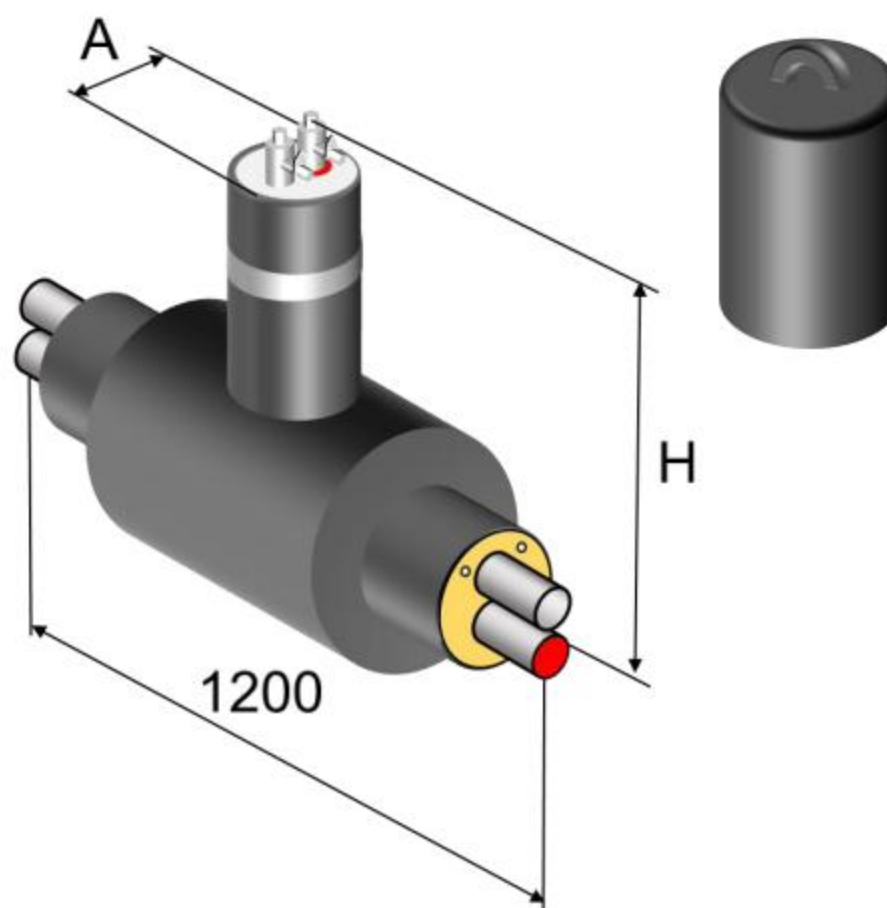

Series 1, 2 and 3

Main pipe DN	H [mm]	Air vent/drain DN	A [mm]
40	451	25	310
50	463	40	310
65	479	50	324
80	495	65	340
100	520		
125	548		
150	581		
200	634		

When making an order it is possible to agree on unit height H.
Tower construction in stainless steel.

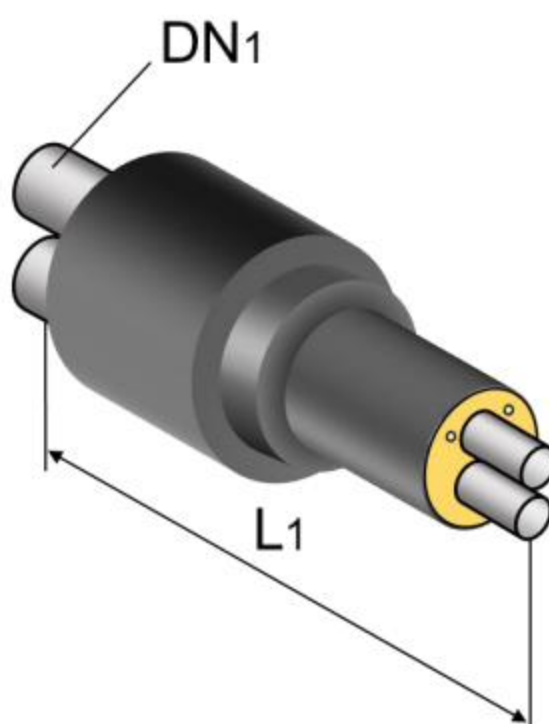

Series 1, 2 and 3

Main pipe DN1	L1 [mm]
32 – 100	1100
125 – 200	1300

Can be ordered with diameter reduction between 1–3-dimension levels.

GALVANISED STEEL CASING PIPES AND FITTINGS 5.0.



Pipes
5.1.1.



House entry pipes
5.1.2.



Bends
5.2.1.



T-branches
5.3.1. – 5.3.3.



Fixed anchors
5.4.1.



Valves
5.5.1.



Air vent/drain units
5.6.1.



Diameter reducers
5.7.1.

Preinsulated pipes in galvanized steel casing

5.1.1.

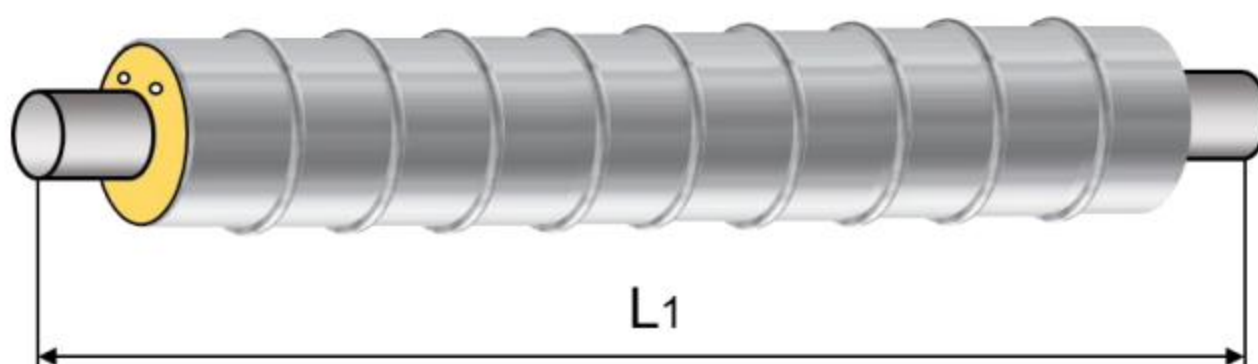

Main pipe DN, mm	Galvanized steel casing		
	Series 1 ØD, [mm]	Series 2 ØD, [mm]	Series 3 ØD, [mm]
20	100	125	160
25	100	125	160
32	100	125	160
40	125	160	180
50	125	160	180
65	160	180	200
80	160	180	200
100	200	225	250
125	225	250	315
150	250	315	355
200	315	355	400
250	400	450	500
300	450	500	560
400	560	630	710
450	560	630	710
500	630	710	800
600	710	800	900
700	800	900	1 000

Can be used in above ground application.

Pipe length **L1** upon request can be 6m, 12m, 16m (DN100-700) or 18m (DN100-400).

Standard carrier pipe material - steel. Also available - copper, stainless steel, seamless pipes, polyethylene.

House entry pipe with metal plug and cable outlet 5.1.2.

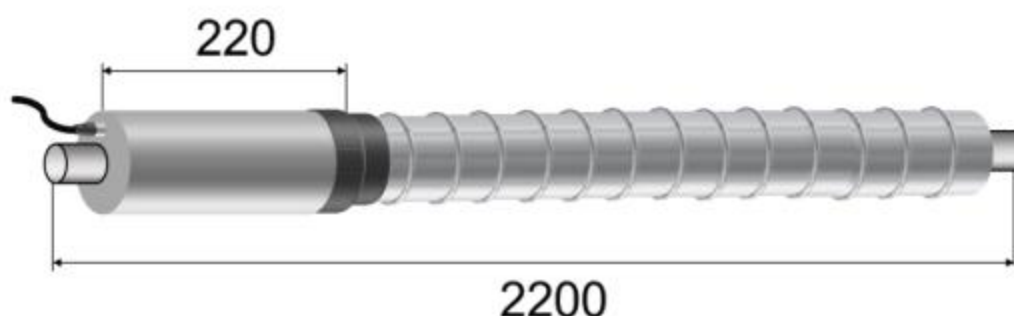

Main pipe DN, mm	Galvanized steel casing		
	Series 1 ØD, [mm]	Series 2 ØD, [mm]	Series 3 ØD, [mm]
20	100	125	160
25	100	125	160
32	100	125	160
40	125	160	180
50	125	160	180
65	160	180	200
80	160	180	200
100	200	225	250
125	225	250	315
150	250	315	355
200	315	355	400
250	400	450	500
300	450	500	560
400	560	630	710
450	560	630	710
500	630	710	800
600	710	800	900
700	800	900	1 000

House entry pipes are used to protect insulated pipes at entrances through building and chamber walls.

The steel end of the inlet pipe is welded to the working pipe and the transition point of the casing with the galvanized tin pipe is sealed with s=140...160 mm wide shrinking tape.

The alarm cables shall be routed from the inlet pipe by a 3,0 m long three-strand cable. On request - without cable lead.

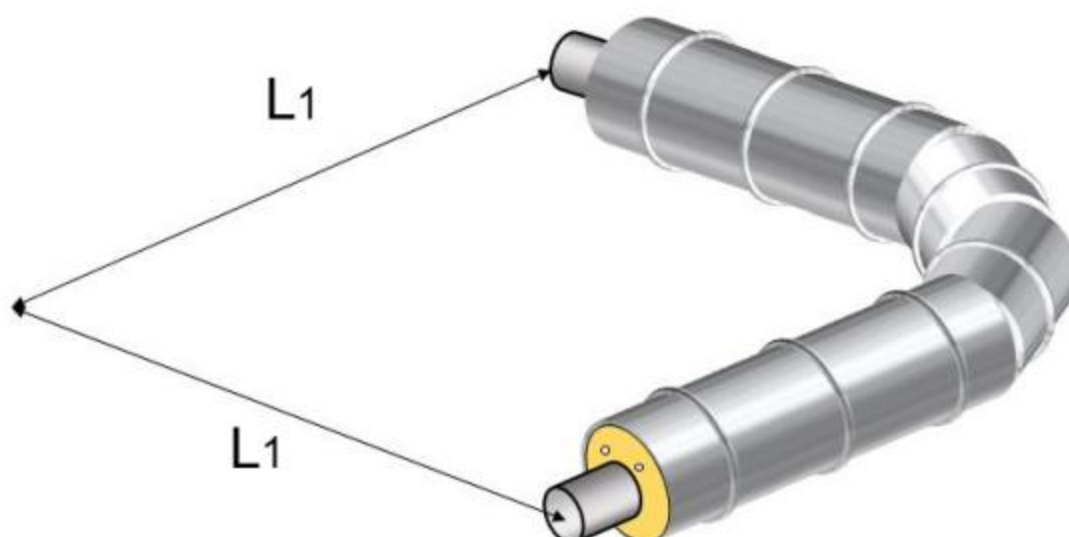

Main pipe DN	Casing pipe, ØD [mm]			L1, [mm]
	Series 1	Series 2	Series 3	
20	100	125	160	1 000
25	100	125	160	1 000
32	100	125	160	1 000
40	125	160	180	1 000
50	125	160	180	1 000
65	160	180	200	1 000
80	160	180	200	1 000
100	200	225	250	1 000
125	225	250	315	1 000
150	250	315	355	1 000
200	315	355	400	1 000
250	400	450	500	1 300
300	450	500	560	1 500
400	560	630	710	1 600
450	560	630	710	1 600
500	630	710	800	1 600
600	710	800	900	1 600
700	800	900	1000	1 700

Standard bend 90°.

Also available:

- Bend degrees 5 - 90°;
- Arm length of L1 up to 10.0 m.

Preinsulated straight T-branches, galvanized steel 5.3.1.

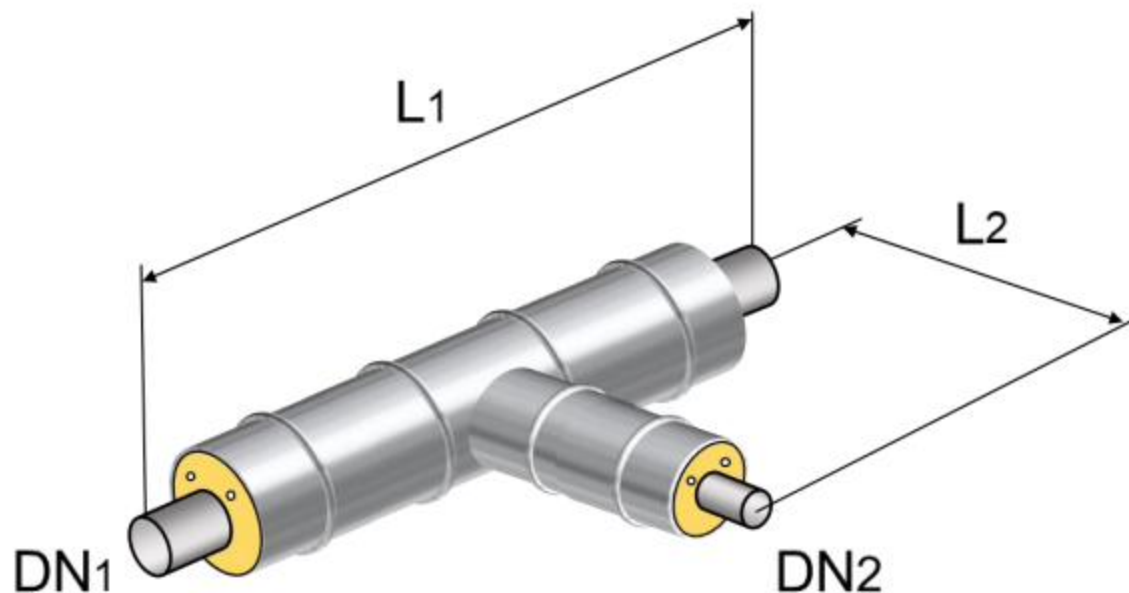

Series 1, 2 and 3

Main pipe DN1	Branch pipe DN2	L1 [mm]	L2 [mm]
20 – 200	20 – 100	1 200	700
125 – 200	125 – 200	1 500	700
250 – 500	25 – 100	1 200	900
250 – 500	125 – 200	1 500	900
250 – 500	250 – 400	1 800	900
600 – 700	25 – 100	1 200	1 100
600 – 700	125 – 200	1 500	1 100
600 – 700	250 – 500	1 800	1 100
600 – 700	600 – 700	2 100	1 100

Diameter of branch **DN2** cannot be greater than diameter of main pipe **DN1**.

On request:

- Can be produced any branch length L1 un L2.

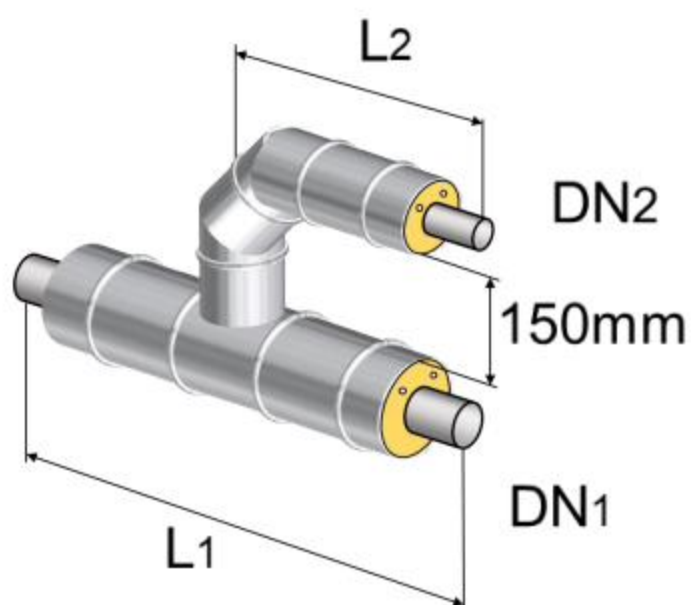
Preinsulated parallel T-branch, galvanized steel**5.3.2.****Series 1, 2 and 3**

Main pipe DN1	Branch pipe DN2	L1, [mm]	L2, [mm]
20 – 150	20 – 100	1 200	600
100 – 700	125 – 200	1 500	750
250 – 700	250 – 400	1 800	900
450 – 700	450 – 500	2 400	1 200
700 – 700	600 – 700	3 000	1 500

Diameter of branch DN2 cannot be greater than diameter of main pipe DN.

On request:

-Can be produced any branch length L1 un L2.

Preinsulated perpendicular T-branch, galvanized steel

5.3.3.

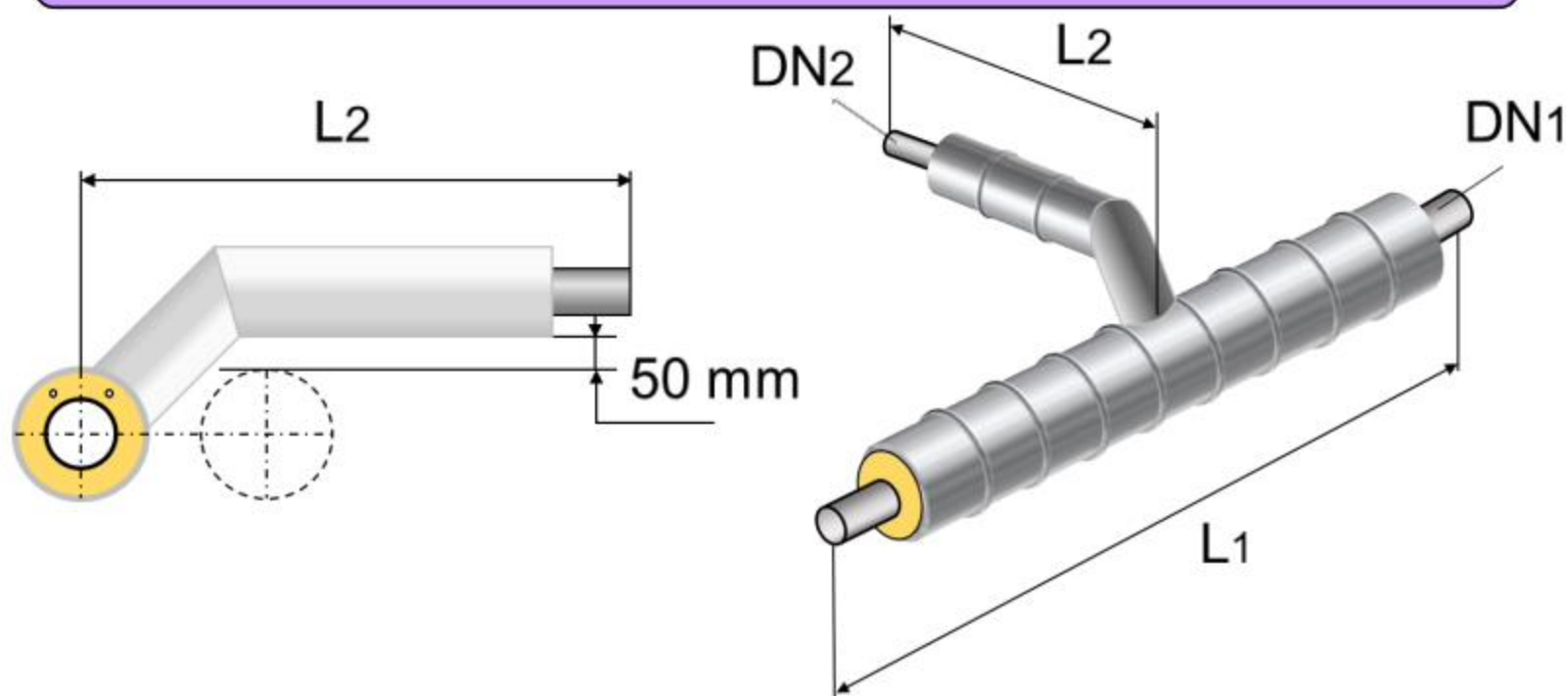

Series 1, 2, 3 and 4

Main pipe DN1	Branch pipe DN2	L1 [mm]	L2 [mm]
20 – 200	20 – 80	1 200	1 000
100 – 200	100 – 200	1 500	1 000
250 – 700	25 – 80	1 200	1 200
250 – 700	100 – 200	1 500	1 200
250 – 700	250 – 400	1 800	1 500
600 – 700	500 – 700	2 100	2 100

Diameter of branch DN2 cannot be greater than diameter of main pipe DN.

On request:

-Can be produced any branch length L1 un L2.

Preinsulated fixed anchors, galvanized steel

5.4.1.

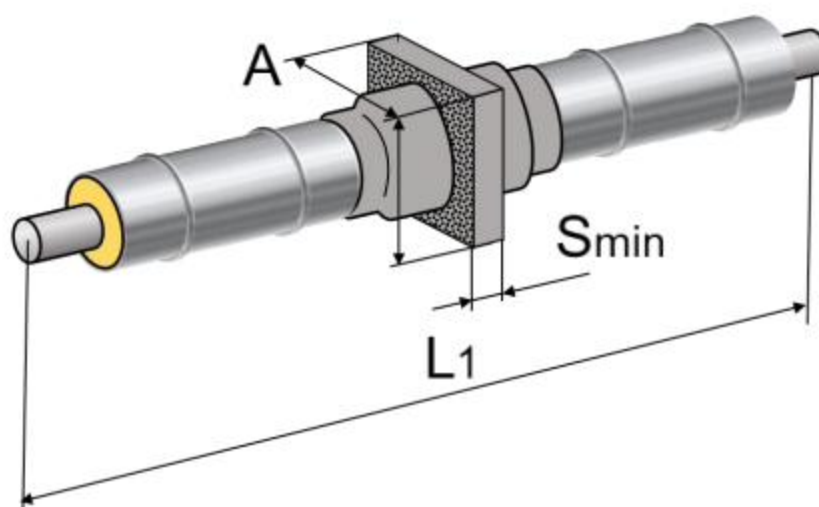

Series 1, 2 and 3

Main pipe DN	Max load kN $\Delta T = 60^{\circ}\text{C}$	A [mm]	S [mm]	Pressure area [cm ²]	L1 [mm]
25	38	240	20	191	2 000
32	49	240	20	243	2 000
40	56	240	20	243	2 000
50	78	260	20	289	2 000
65	100	280	25	452	2 000
80	129	300	25	392	2 000
100	187	350	25	565	2 000
125	230	380	25	765	2 000
150	310	415	25	875	2 300
200	455	500	30	1 385	2 300
250	630	600	30	1 730	2 300
300	840	660	30	1 885	2 300
400	1 200	810	40	2 560	2 500
500	1 500	900	40	4 000	2 500
600	2 000	1 000	50	6 200	3 000

Anchor plate next to working pipe is strengthened with additional steady ribs.

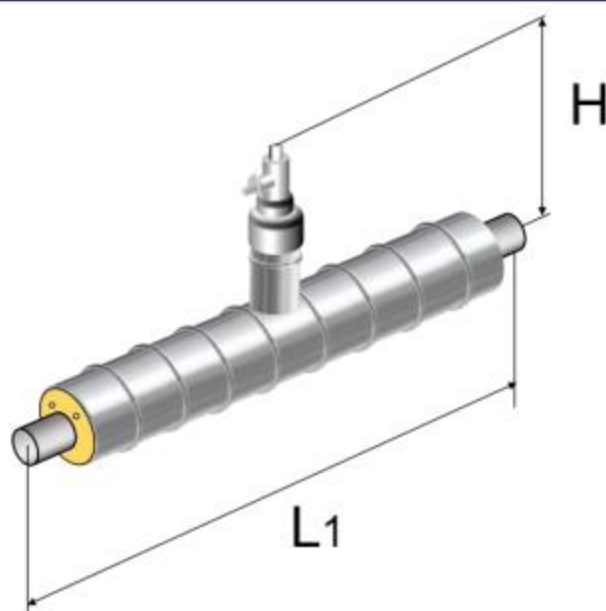

Series 1, 2 and 3

Main pipe DN	Service valve				L1, [mm]
	Air release unit DN, mm	A, [mm]	Drainage units DN, mm	A, [mm]	
25	20	110	20	90	1 000
32	20	110	25	110	1 000
40	20	110	32	125	1 000
50	25	110	32	125	1 000
65	25	110	32	125	1 000
80	32	125	40	125	1 000
100	32	125	50	140	1 000
125	40	125	50	140	1 000
150	40	125	80	180	1 200
200	50	140	100	225	1 200
250	50	140	100	225	1 200
300	50	140	100	225	1 200
350	65	160	125	225	1 200
400	65	160	125	225	1 200
450	65	160	125	225	1 200
500	65	160	150	250	1 200
600	80	180	200	315	1 400
700	80	180	200	315	1 400
800	100	225	250	400	1 400

Use as bleed or drain valve.

Minimum stem height $H_{min} = 400$ mm.

On request:

- with higher stem height H;
- with stainless steel cap and PE cover;
- other service valve sizes in relation to the main pipe.



Preinsulates valve without stem, galvanized steel

5.6.1.

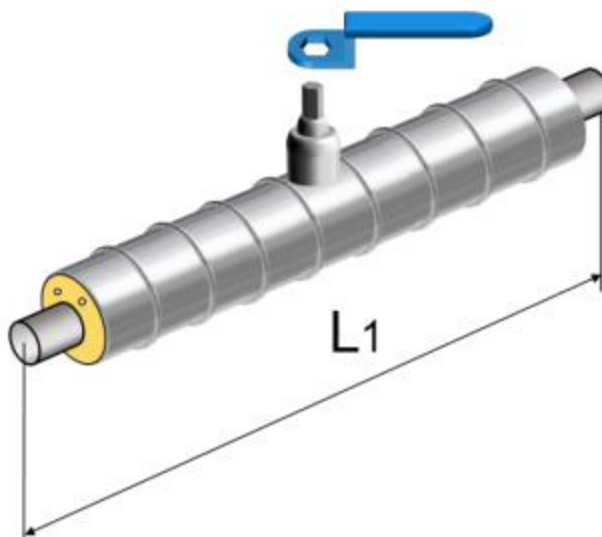

Series 1, 2 and 3

Main pipe DN, mm	L1, [mm]	Wrench size, [mm]
25	1 500	19
32	1 500	19
40	1 500	19
50	1 500	19
50	1 500	19
65	1 500	19
80	1 500	19
100	1 500	27
100	1 500	27
125	1 500	27
125	1 500	27
150	1 500	27
150	1 500	27
200	1 500	50
250	1 500	50
300	1 800	50

On request:

- different length L1.

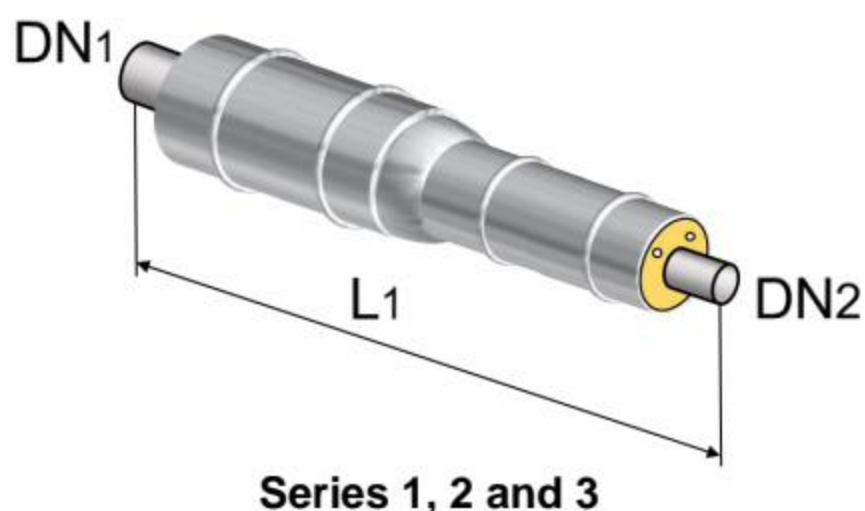

Main pipe DN1	L1 [mm]
25 – 200	1 000
250 – 400	1 200
400 – 700	1 200

The standard DN1-DN2 transition is 1-2 sizes smaller than the main pipe. (e.g. 168 to 139 or 114).

On request:

- different length L1';
- with the desired series casing (galvanized tin casing DN1 and DN2 may be different);
- with a higher degree of reduction.



**Double expanded
shrinkable joint**
L = 700 mm



**Double expanded
shrinkable extended
joint**
L > 700 mm



**Double sealed
reduction joint**
L = 900 mm



Baloon joint
L = 900 mm



Baloon joint
L = 1 400 mm



Mittel joint
L = 700 mm
split open / not split open



Mittel joint
L ≥ / ≤ 700 mm
split open / not split open



**Double sealed
joint**
L = 700 mm



**Double sealed
extended joint**
L > 700 mm



Electro welding joint
L = 700 mm



Heat shrinkable flexible joint
L = 815 - 1 225 mm



T – joint flexible
L = 1000 - 1200 mm



T – joint straight
L = 700 mm



Double sealed Termination joint
L = 700 mm



Double sealed extended termination joint
L > 700 mm



Measure joint
L = 700 mm



Double sealed baloon joint
L = 900 mm



Double sealed extended baloon joint
L > 900 mm



T – joint for connection single/double
L = 900 mm



Spiro casing joint

Connection materials with heat-shrinkable sleeve 6.1.1.

- with polyurethane foam component «A» and «B»:

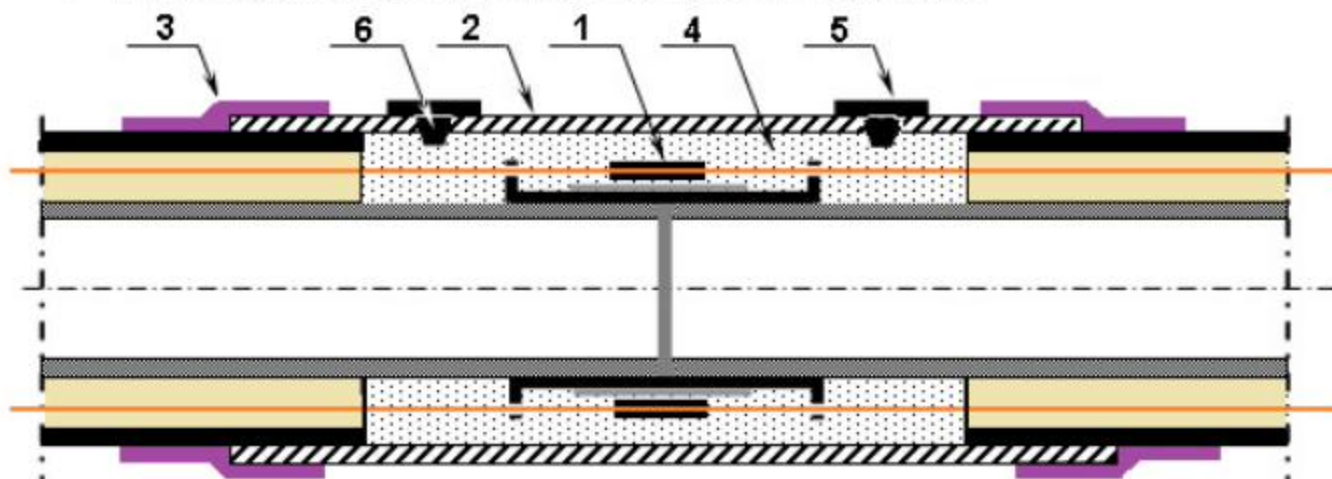

Station number	Description	Material quantity for 1 connection, pcs
1.	Alarm wire connectors	2
2.	Heat-shrinking sleeve	1
3.	Heat-shrinking manchettes	2
4.	Polyurethane foam components «A»&«B»*	2
5.	PE venting cork D26 **	2
6.	PE welding cork **	2
7.	FOPS patches	2

Note:

* Depending on the order, PUR foam components "A" and "B" are packed in small volume containers with quantities per compound;

** PE welded corks (station 6) are welded in after the filling up of the joint with PUR foam.

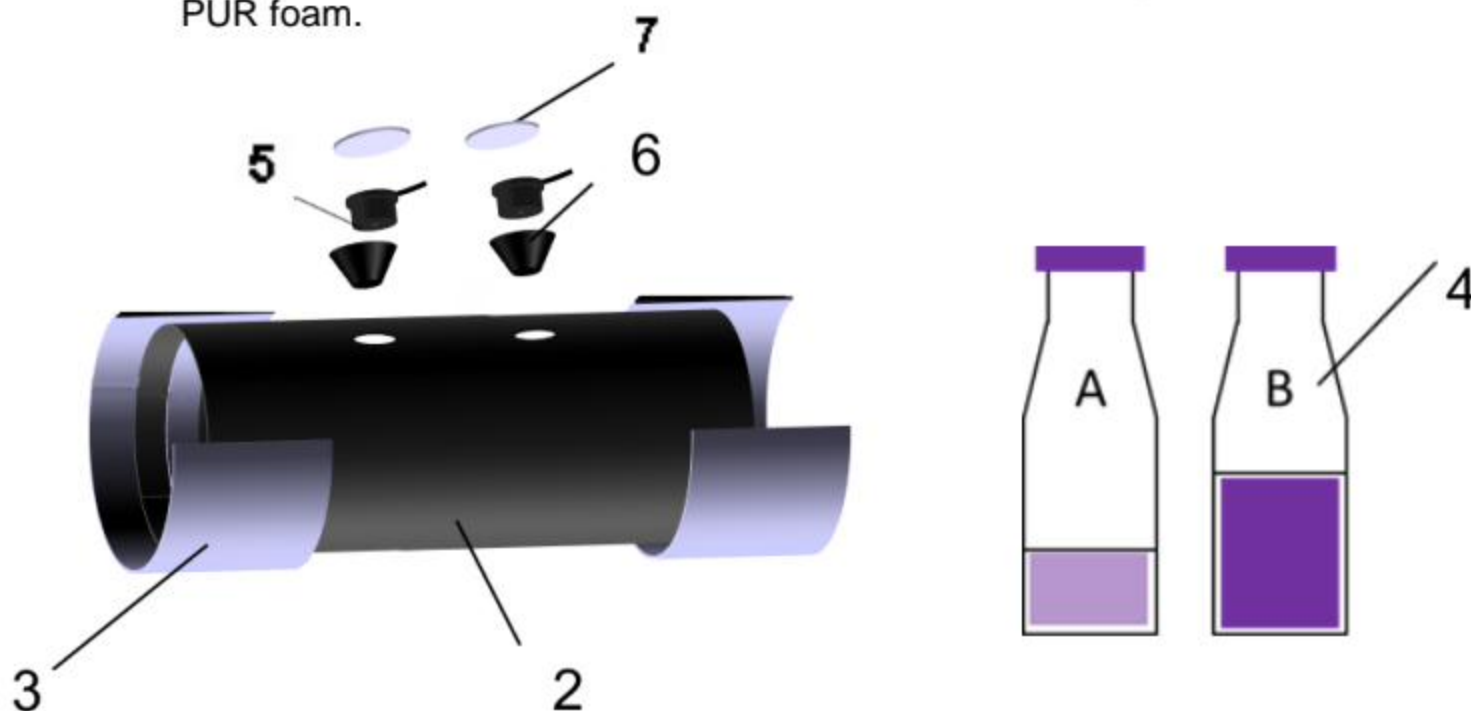



Small gas burner



Sand paper



Crimping pliers



Flat nose pliers



Cleaning liquid

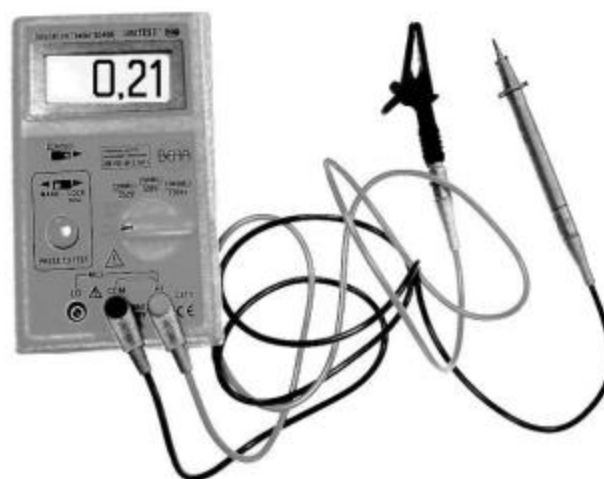

Megameter

Alarm system assembly tools

6.2.2.



Gas hose with reducer



Cork welding device



Conical drill \varnothing 28
With distance sleeve



Scraper



Knife with
replaceable blade



Paper towels



Measuring tape



Component mixer



drill \varnothing 25 MM

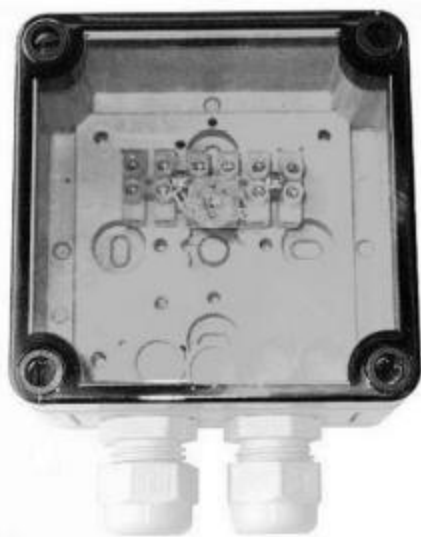

Alarm box



Cable



Tape



Alarm wire connectors



Tin

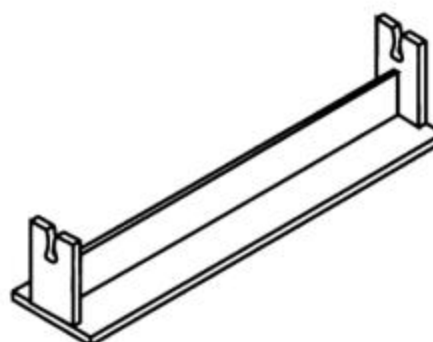

Alarm wire holders

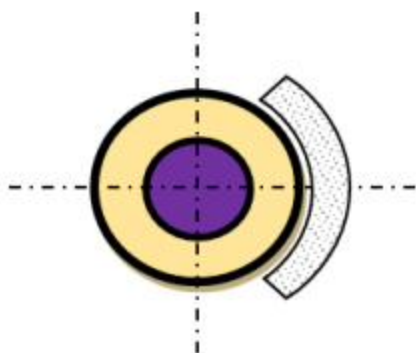

Foam pads

7.1.



End caps

7.2.



End seal

7.3.



Elastic seal

7.4.

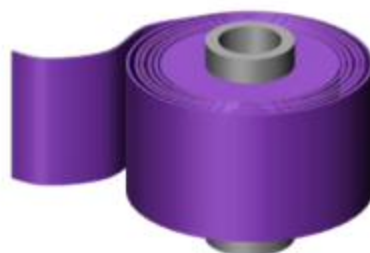

Warning tape

7.5.



Warning net

7.5.

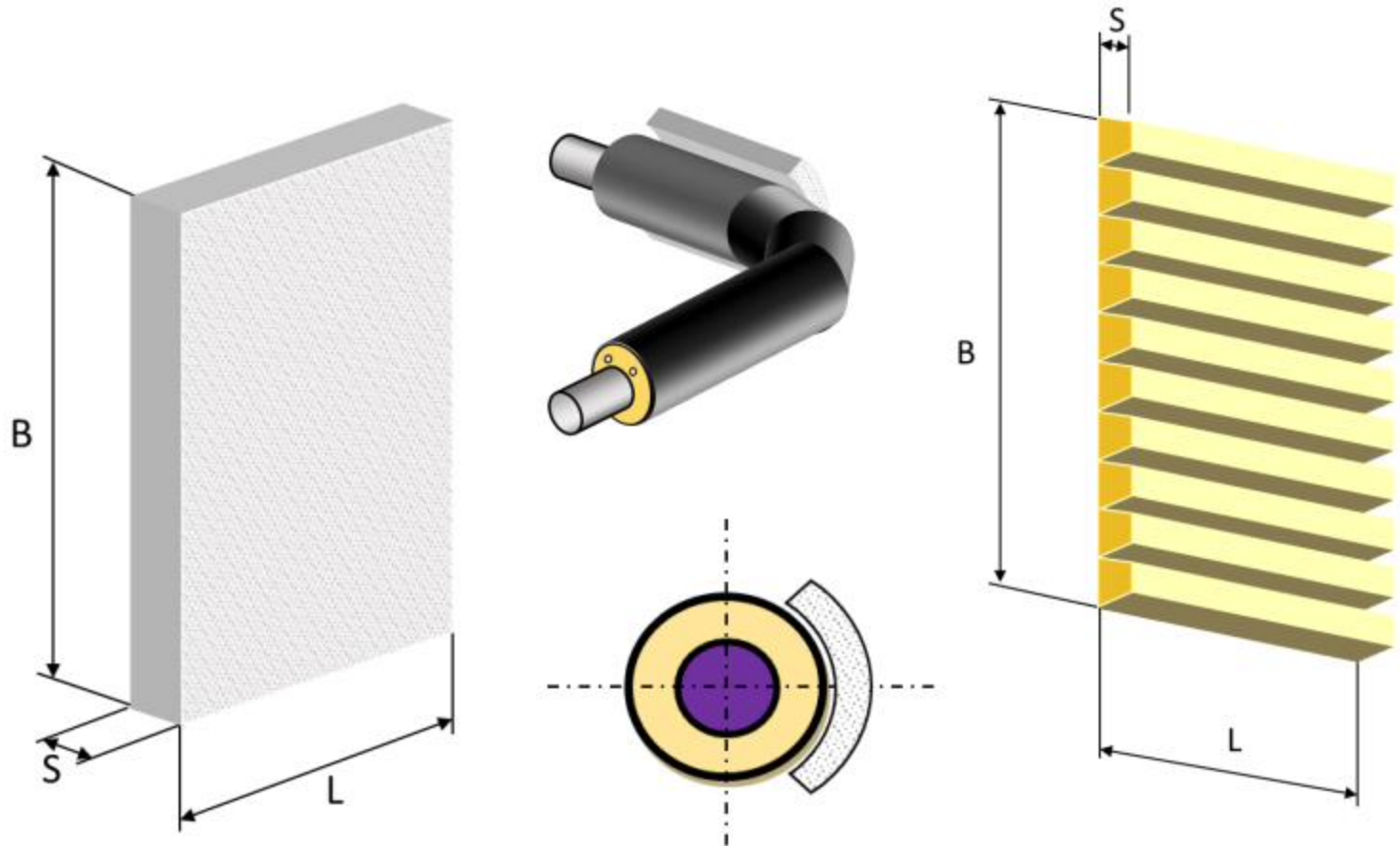

Length L, mm	Width B, mm	Thickness s, mm
2000	1200	50

Foam pads are placed to capture deformation of thermal elongation of the straight pipeline. Pads are produced from flexible material.

Foam pads are placed at the end of straight pipe segments on the outer and inner side of the fitting and are strengthened using duct tape, cord, or any material of such sort.

Foam pads are cut by outer diameter of pipe casing:

Diameter of PE casing [mm]	Width of pad C [mm]	Diameter of PE casing [mm]	Width of pad C [mm]	Diameter of PE casing [mm]	Width of pad C [mm]
90	143	225	300	500	715
110	166	250	333	560	790
125	182	280	370	630	870
140	200	315	430	710	1000
160	222	355	500	800	1130
180	250	400	570	900	1400
200	285	450	665	1000	1500

End cap is heat-shrinkable product that has cylindrical gradually degreasing shape.

End cap is placed at pipe ends to seal PUR insulation after entering buildings, foundation or canals.

End cap are used for one preinsulated steel pipe as well as for preinsulated twin steel pipe system.

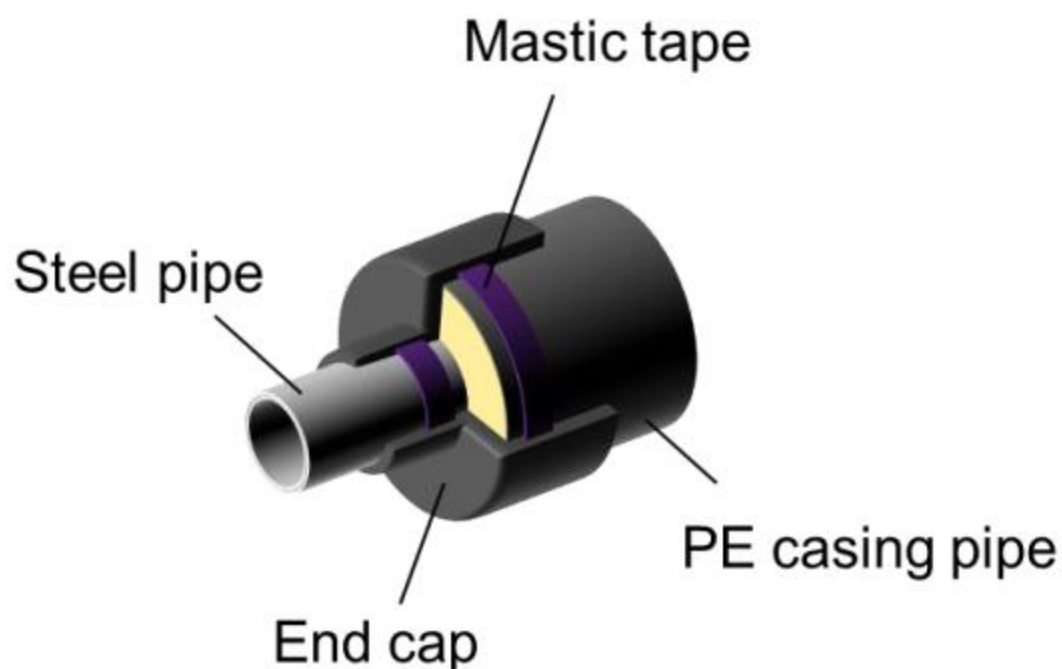

End caps are used for preinsulated pipes with heating pipe temperature not exceeding 135°C.

Single pipes**Twin pipes**

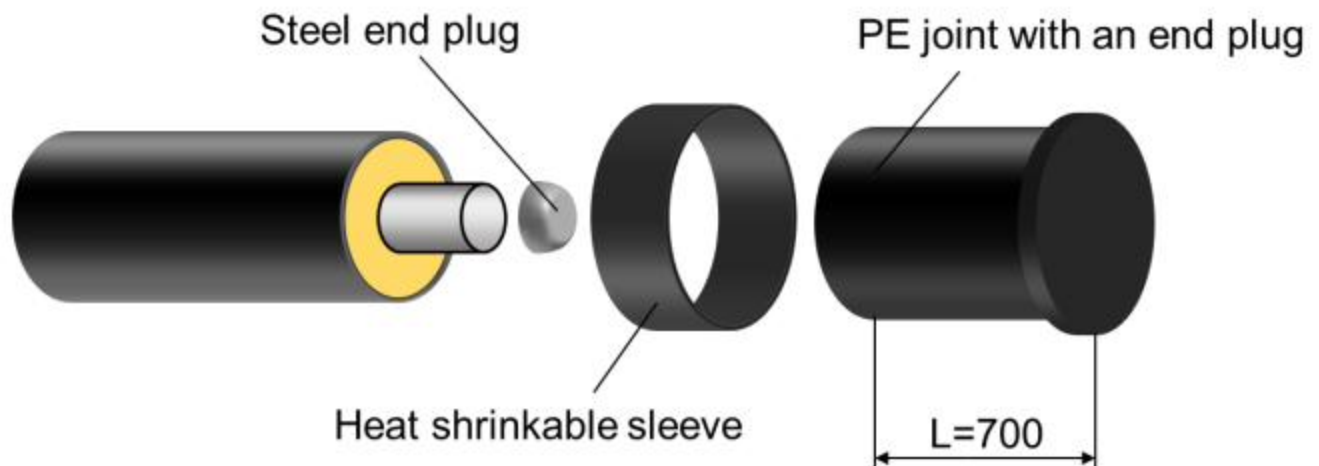

End plugs are used for sealing preinsulated pipe ends that can be extended in the future.

PE sleeve connection to end plug and pipe casing is secured using heat-shrinkable tape. Space under the PE sleeve is filled with rock wool or foam.

Performance in twin pipe system:



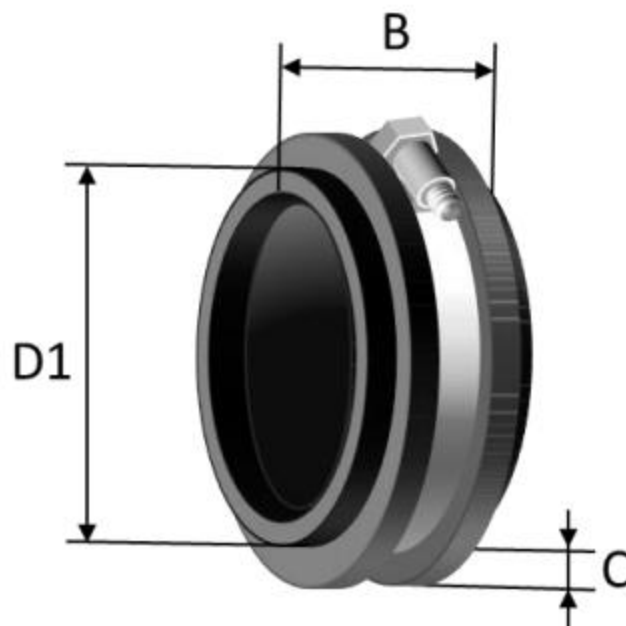

Dimension D1 [mm]	B [mm]	C [mm]
90 - 180	40	22
200 - 1000	50	27

Wall entry rings are used where pipes pass through walls or floor entries to prevent the penetration of ground water in buildings. Rings are made from special rubber profile resistant to ageing.

Location of the F802 in concrete If holes is to be drilled in the concrete wall for later embedding of pipes/rubber ring in concrete.

Recommend min. drill holes:

HDPE 40 – 180	Jacket dim.	+ 100 mm
HDPE > 200	Jacket dim.	+ 120 mm

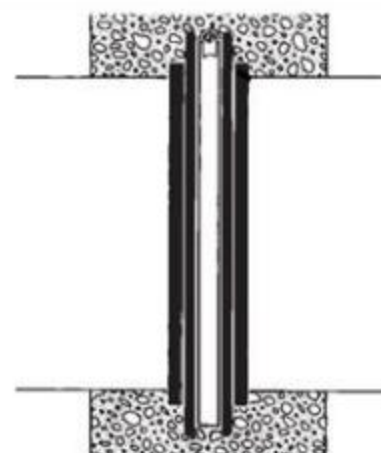

Position between the wall and pipe

When mounting in other types of holes, there should be a clear space above the rubber ring of 20 mm.

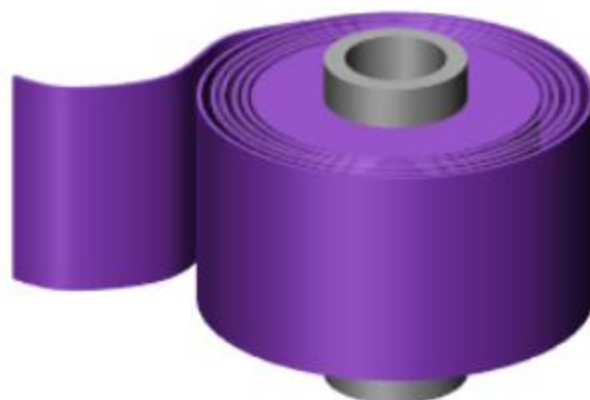

Warning Tape

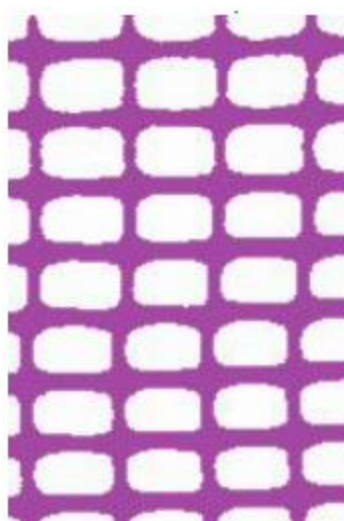

Warning net

Warning tape and net is used to warn and locate the pipeline during earthwork.